



**CS-700**

**Owner's Manual**



# Table of Contents

## Chapter 1: Connecting Your System

Reading this Manual .....	1
Step-by-Step Connections .....	1
Step 1: Unpack the box.....	2
Step 2: Put the batteries in the remote control .....	2
Step 3A: Set-top box connection .....	3
Step 3B: TV audio connection.....	4
Step 4: Connect Klipsch System to the TV's Input.....	5
Step 5: Connect the speakers.....	6
Speaker Setup Considerations.....	6
Step 6: Connect other components (OPTIONAL) .....	7
Step 7: Connect AM and FM antennas.....	8
Step 8: Turn on the TV and the Klipsch system.....	8
Step 9: Complete the on-screen setup .....	9
Your Klipsch Controller.....	11
Buttons .....	11
Display .....	11
The basics .....	12
Switching between media— TV, DVD, Radio, CD, etc.....	12

## Chapter 2: Remote Control

Buttons.....	13
Programming your remote control.....	14

## Chapter 3: Operation

Compatible discs .....	15
Incompatible discs .....	15
Regional coding.....	15
Playing a disc .....	15
DVD and VCD playback.....	16
Transport.....	16
Navigating info banners .....	17
Playing CDs .....	18
Playing CDs with mp3 or JPEG files.....	19
Playing the radio .....	19
Setting up presets .....	19
On screen info banner.....	19

## Chapter 4: Menu System

On screen menu system .....	20
Navigating menus.....	20
On-screen menus .....	21
Audio.....	21
Setup .....	21
Languages.....	21
Parental control .....	22
Remote control .....	22

## Chapter 5: Troubleshooting

General problems.....	23
Video problems .....	23
Audio problems.....	23
Remote control problems.....	23
Playback problems.....	23
Radio problems.....	23

## Chapter 6: Care and Maintenance

Klipsch System.....	24
Cleaning.....	24
Handling and Caring for Discs.....	24
Remote Control Codes.....	25
Warranty.....	27
FCC Information .....	27

## Appendix I

Connection Overview.....	28
Input jacks .....	28
Output jacks.....	28
Audio connection options .....	28
Video connection options .....	28

## Important Safety Information

1. READ these instructions.
2. KEEP these instructions.
3. HEED all warnings.
4. FOLLOW all instructions.
5. DO NOT use this apparatus near water.
6. CLEAN ONLY with dry cloth.
7. DO NOT block any ventilation openings. Install in accordance with the manufacturer's instructions.
8. DO NOT install near any heat sources such as radiators, heat registers, stoves, or other apparatus (including amplifiers) that produce heat.
9. DO NOT defeat the safety purpose of the polarized or grounding type plug. A polarized plug has two blades with one wider than the other. A grounding type plug has two blades and a third grounding prong. The wider blade or the third prong is provided for your safety. If the provided plug does not fit into your outlet, consult an electrician for replacement of the obsolete outlet.
10. PROTECT the power cord from being walked on or pinched, particularly at plugs, convenience receptacles, and the point where they exit from the apparatus.
11. ONLY USE attachments/accessories specified by the manufacturer.
12. USE only with a cart, stand, tripod, bracket, or table specified by the manufacturer, or sold with the apparatus. When a cart is used, use caution when moving the cart/apparatus combination to avoid injury from tip-over. 
13. UNPLUG this apparatus during lightning storms or when unused for long periods of time.
14. REFER all servicing to qualified service personnel. Servicing is required when the apparatus has been damaged in any way, such as power-supply cord or plug is damaged, liquid has been spilled, objects have fallen into the apparatus, the apparatus has been exposed to rain or moisture, does not operate normally, or has been dropped.

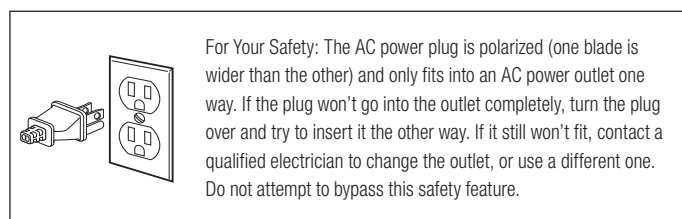

15. DO NOT expose this apparatus to dripping or splashing and ensure that no objects filled with liquids, such as vases, are placed on the apparatus.
16. To completely disconnect this apparatus from the AC Mains, disconnect the power supply cord plug from the AC receptacle.
17. The mains plug of the power supply cord shall remain readily operable.



The exclamation point, within an equilateral triangle is intended to alert the user to the presence of important operating and maintenance (servicing) instructions in the literature accompanying the product.



The lightning flash with arrowhead symbol within an equilateral triangle, is intended to alert the user to the presence of uninsulated "dangerous voltage" within the product's enclosure that may be of sufficient magnitude to constitute a risk of electrical shock to persons.

WARNING: To reduce the risk of fire or electrical shock, do not expose this apparatus to rain or moisture.

WARNING: Batteries (battery pack or batteries installed) shall not be exposed to excessive heat such as sunshine, fire or the like.

WARNING: No naked flame sources – such as candles – should be placed on the product.

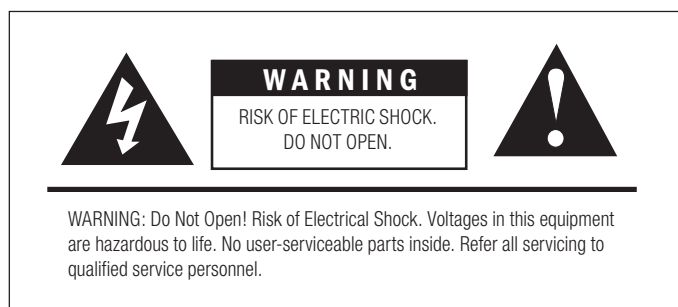

WARNING: This product is intended to be operated ONLY from the AC Voltages listed on the back panel or included power supply of the product. Operation from voltages other than those indicated may cause irreversible damage to the product and void the product's warranty. The use of AC Plug Adapters is cautioned because it can allow the product to be plugged into voltages in which the product was not designed to operate. If the product is equipped with a detachable power cord, use only the type provided with your product or by your local distributor and/or retailer. If you are unsure of the correct operational voltage, please contact your local distributor and/or retailer.

CAUTION: Place the equipment near a main power supply outlet and make sure that you can easily access the power breaker switch.

NOTE: If the AC mains connection provides a third prong for ground (Class 1 devices), the device shall be connected to a main socket outlet with a protective earthing connection.

NOTE: If a DVD is present, the following laser safety statement applies:

LASER SAFETY: This unit employs a laser. Due to possible eye injury, only a qualified service person should remove the cover or attempt to service this device.

CAUTION: Use of controls or adjustments or performance of procedures other than those specified herein may result in hazardous radiation exposure.

This device is protected by U.S. patent numbers 4,631,603 and 4,577,216 and 4,819,098 and 4,907,093 and other intellectual property rights.

### DVD Safety Information

This DVD player is designed and manufactured to respond to the Region Management Information. If the region number of a DVD disc does not correspond to the region number of this DVD player, this player cannot play the disc. The region number for this DVD player is Region No 1.

### DVD Copy Protection

In accordance with the DVD standard, your DVD player is equipped with a Copy Protection System, which can be switched on and off by the DVD disc itself, in order to make any recording of the relevant DVD disc onto a videotape of very poor picture quality, or even impossible. This product incorporates copyright protection technology that is protected by method claims of certain U.S. patents and other intellectual property rights owned by Macrovision Corporation and other rights owners. Use of this copyright protection technology must be authorized by Macrovision Corporation, and is intended for home use only unless otherwise authorized by Macrovision Corporation. Reverse engineering or disassembly is prohibited. This DVD player does not play discs that are pirated. The unauthorized use and recording of copyright and patented material is considered piracy.

## Thank You

Thank you for purchasing the Klipsch CS-700 System. After reading this manual and connecting your system, you will hear the results of more than 60 years of stringent engineering and class-leading research and development. Like all Klipsch products, your Klipsch CS-700 features Klipsch Tractrix® Horn-loaded technology—the guiding design for the first Klipschorn® developed in 1946 and every product that has followed. Horn-loading allows your speakers

to deliver high sensitivity, low distortion, flat frequency response and wide dispersion, which translates to unequalled power, detail, and dynamics: the hallmark of the “Klipsch Sound.” Please be sure to return the enclosed product registration card or register your product at [www.klipsch.com](http://www.klipsch.com) so we are better able to serve you. Again, thank you for choosing Klipsch and we hope that your Klipsch CS-700 brings life to your music and movies for many years.

## Reading this Manual

This manual uses different style conventions and typefaces to distinguish them from the body text. Throughout the manual, the following conventions are used:

Text	Example
Button names on the remote and unit appear in <b>ALL CAPS, BOLD</b> .	<b>DISC, AUX 1, SAT/CAB, GUIDE, INFO, DVD MENU</b>
On-screen menus appear in <b><i>Bold, Italics</i></b> .	<b><i>Audio, Setup, Languages, Parental Control</i></b>
Input and output jack names appear in ALL CAPS.	AUX 1 INPUT, VIDEO OUTPUT, COMPONENT
Black bar sections provide technical information.	<b>Input and Output Jacks</b>

## CHAPTER 1: CONNECTING YOUR SYSTEM













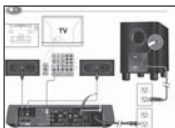

### Step-by-Step Connections

This chapter is divided into steps to get you up and running as quickly as possible. Because TVs have so many different options these days, several connection scenarios are provided. Below is a summary of the steps you will take to get connected.

Step 1: Unpack the box	Page 2
Step 2: Put batteries in the remote control	Page 2
Step 3: Connect TV signal output to Klipsch input	
3A: Set-top box Connection	Page 3
Use this connection if your TV has a cable box, satellite receiver, or HD Receiver set-top box connected to it	
3B: TV Audio Connection	Page 4
Use this connection if you receive your TV signal via regular cable (no cable box) or an off-air antenna	
Step 4: Connect Klipsch system to TV's VIDEO INPUT	Page 5
Step 5: Connect the speakers	Page 6
Step 6: Connect other components	Page 7
Step 7: Connect AM and FM antennas	Page 8
Step 8: Turn on TV and Klipsch system	Page 8
Step 9: Complete the on-screen setup	Page 9

### STEP 1: Unpack the box

Make sure you have the following items as you unpack your Klipsch system.

<input type="checkbox"/>  Controller	<input type="checkbox"/>  Subwoofer	<input type="checkbox"/>  Left/Right Speakers	<input type="checkbox"/>  Setup Guide	<input type="checkbox"/>  Owner's Manual
<input type="checkbox"/>  Remote Control	<input type="checkbox"/>  2 AA Remote Batteries	<input type="checkbox"/>  Composite Video Cable (Yellow)	<input type="checkbox"/>  Left/Right Audio Cable Red and White	<input type="checkbox"/>  FM Antenna
<input type="checkbox"/>  AM Antenna	<input type="checkbox"/>  2 20-Ft. Left/Right Speaker Cables	<input type="checkbox"/>  Subwoofer Power Cable	<input type="checkbox"/>  Mini plug to RCA Adapter	<input type="checkbox"/>  Rubber Pads

### Step 2: Put the batteries in the remote control

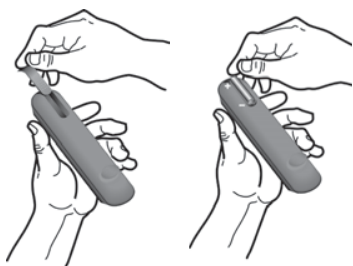

1. Locate supplied remote control and batteries.
2. Remove the battery compartment cover on the back of the remote. Push down on the tab and lift the cover.
3. Insert the two (2) "AA" batteries. Make sure the polarities (+ and -) are aligned correctly with the polarities inside the remote.
4. Replace the cover.

### STEP 3A: Set-Top Box Connection

Use this connection if your TV has a cable box, satellite receiver or HD receiver set-top box connected to it. See next page (3B) if no set-top box is used.

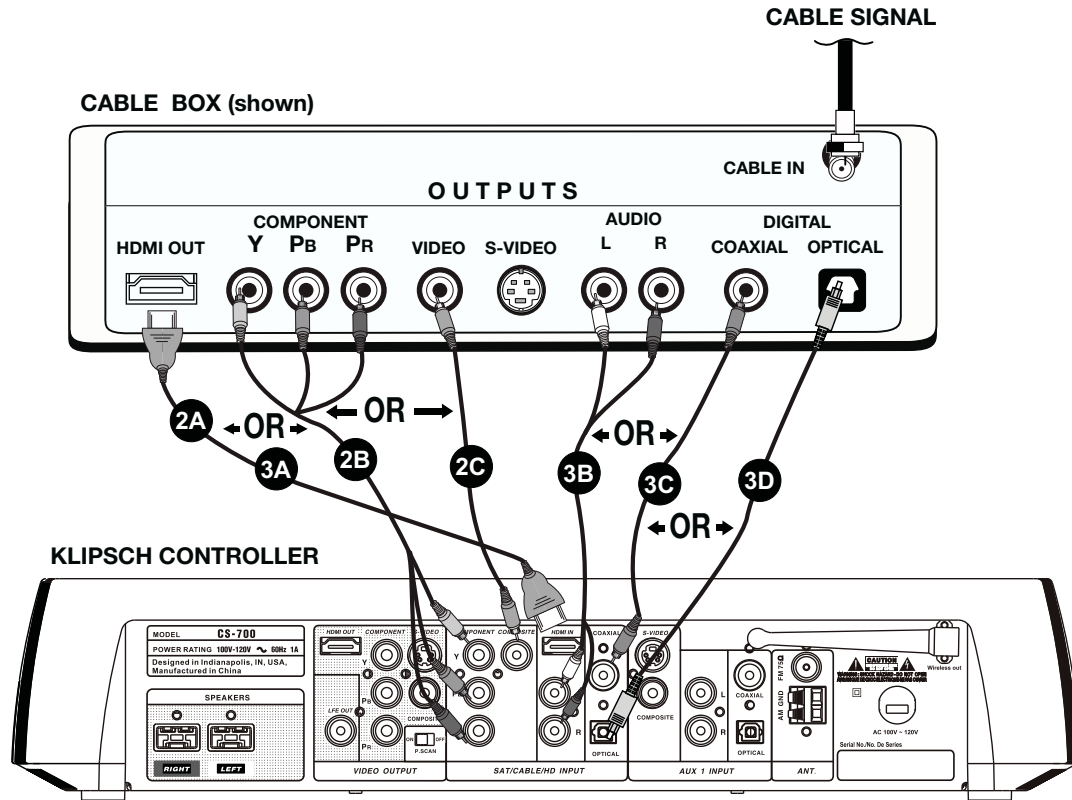

1. Disconnect the cable on your cable, satellite or HD set-top box that is connected to your TV (you need to connect 1 video and 1 audio).
2. Connect the VIDEO—look at the options available on the set-top box and choose 2A, 2B or 2C.
  - A. B. To maintain best picture quality—if the back of the set-top box has HDMI or COMPONENT VIDEO (Y, Pb, Pr) OUTPUT jacks, plug corresponding cable(s) into the jack(s) on the set-top box and to the Klipsch system's SAT/CABLE/HD INPUT HDMI or COMPONENT jacks (Y to Y; Pb to Pb, Pr to Pr). If you use 2A or 2B, you must also connect the corresponding output from the Klipsch controller's "VIDEO OUTPUT" section to your TV to ensure that you get a picture. These cables have not been included with the Klipsch system. When using the HDMI connections you must turn Progressive Scan (P. SCAN) "On". If the HDMI connections are used and P. SCAN is "Off", you will not see a picture.
  - C. If the set-top box has a VIDEO (yellow) OUTPUT jack for video, plug the supplied yellow video cable into that jack and to the Klipsch system's SAT/CABLE/HD INPUT COMPOSITE (yellow) jack.
3. Connect the AUDIO—look at the options available on the set-top box and choose 3A, 3B, 3C or 3D.
  - A. If an HDMI cable is used, audio is already connected through this cable.
  - B. Connect the supplied audio cables to the AUDIO LEFT (white) and AUDIO RIGHT (red) jacks on the back of the set-top box and to the Klipsch system's SAT/CABLE/HD INPUT LEFT (white) and RIGHT (red) jacks.
  - C. If the set-top box has Digital AUDIO (COAXIAL), connect appropriate cable to the set-top box AUDIO COAXIAL jack and to the SAT/CABLE/HD INPUT COAXIAL jack.
  - D. If the set-top box has Digital AUDIO (OPTICAL), connect appropriate cable (not supplied) to the Klipsch System's SAT/CABLE/HD INPUT OPTICAL jack. You will first need to remove the plastic dust plug.

*Note: If you connect a high definition Y, Pb, Pr INPUT, you must also connect the corresponding Y, Pb, Pr OUTPUT to your TV. If you connect a HDMI, you must also connect the corresponding output from the Klipsch controller's "VIDEO OUTPUT" section to your TV to ensure that you get a picture. These cables have not been included with the Klipsch system.*

#### Input and Output Jacks

Please see appendix I (page 28) for the basics on how input and output jacks work with your Klipsch system.

### STEP 3B: TV Audio Connection

Use this connection if you receive your TV signal via regular cable (no cable box) or with an off-air antenna.

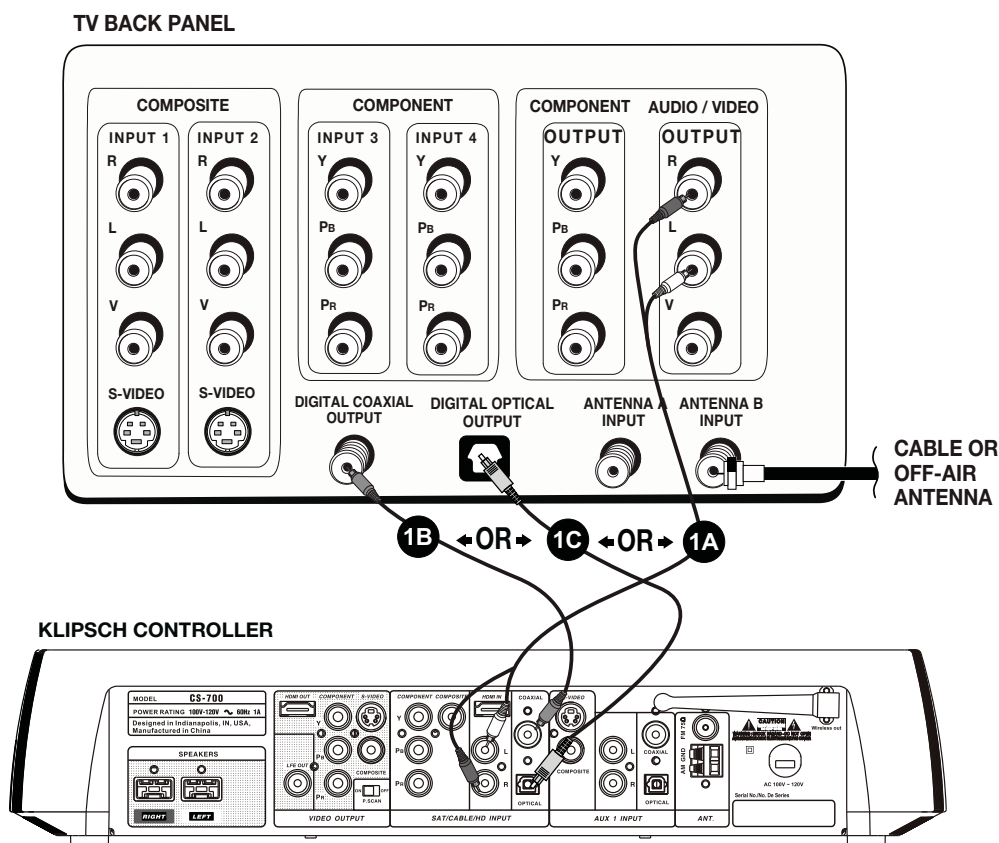

If you don't have a set-top box connected to your TV (you either have cable coming out of the wall or an off-air antenna, such as HD), simply connect the Audio OUTPUT jacks on the TV to the AUDIO INPUT jacks on the Klipsch system. If you want the TV sound to come through the Klipsch system, you need to make this audio connection.

1. Choose the best TV AUDIO connection available (1A, 1B, or 1C).
  - A. If your TV doesn't have DIGITAL OPTICAL or DIGITAL COAXIAL for the audio connection, connect standard audio cables (you can use the supplied cables for this if you have not already used them) to the AUDIO LEFT (white) and AUDIO RIGHT (red) OUTPUT jacks on the back of your TV and to the Klipsch system's SAT/CAB/HD INPUT jacks that are labeled L and R.

- B. If your TV has a DIGITAL AUDIO (COAXIAL) OUTPUT jack, connect appropriate cable (not supplied) to the TV's AUDIO COAXIAL OUTPUT jack and to the Klipsch System's SAT/CAB/HD INPUT COAXIAL jack.
- C. If your TV has a DIGITAL AUDIO (OPTICAL) OUTPUT jack, connect appropriate cable (not supplied) to it and the other end to the Klipsch System's SAT/CAB/HD INPUT OPTICAL jack.

2. Make note of which AUDIO INPUT you used (SAT/CAB, AUX 1, AUX 2), as you will need to enter the correct AUDIO INPUT setting during the on-screen setup procedure in Step 9.

**Input and Output Jacks**

Please see appendix I (page 28) for the basics on how input and output jacks work with your Klipsch system.



## STEP 4: Connect Klipsch System to the TV's Input

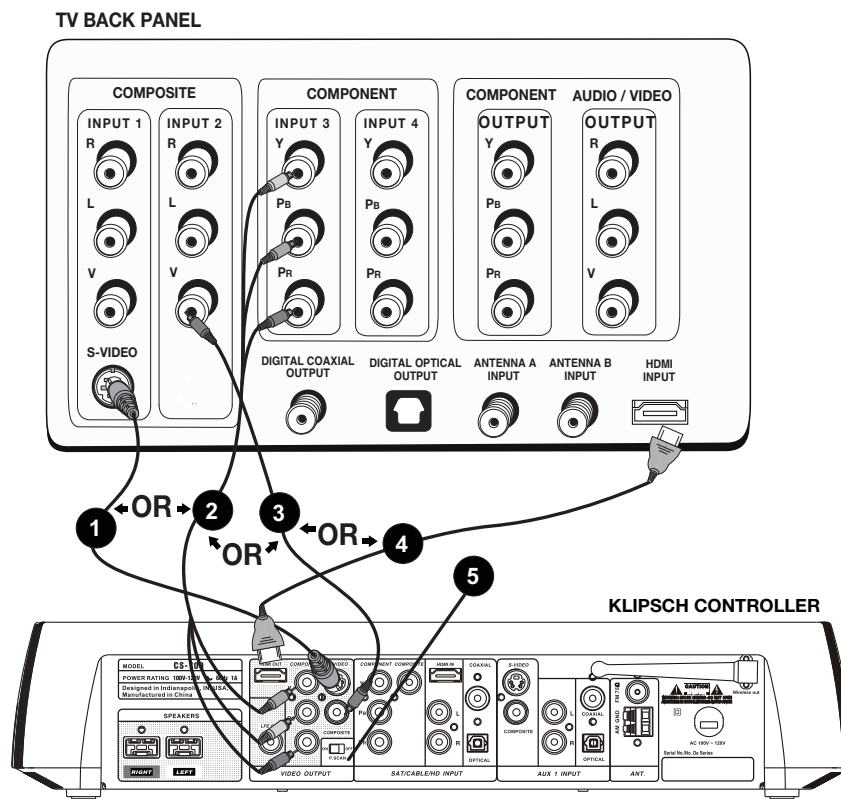

1. If your TV doesn't have HDMI or COMPONENT, but has S-VIDEO, connect S-VIDEO cable (not supplied) to the Klipsch system's VIDEO OUTPUT S-VIDEO jack and to the corresponding S-VIDEO jack on the TV.
2. If your TV has COMPONENT INPUT jacks (Y, Pb, Pr) connect the (not supplied) corresponding cables (either bundled or three separate video grade cables—yellow) to the Klipsch system's VIDEO OUTPUT COMPONENT Y, Pb, Pr jacks and to the corresponding input jacks on the TV. To use this option, you must also connect the corresponding Y, Pb, Pr OUTPUT to your TV.
3. If your TV doesn't have COMPONENT or S-VIDEO, connect the TV's VIDEO INPUT (yellow) to the Klipsch system's COMPOSITE jack (yellow) with the supplied cable.

4. If your TV has an HDMI INPUT, connect the corresponding HDMI cable (not supplied) from the HDMI OUTPUT of the Klipsch system to the HDMI INPUT of the TV.
5. If you're using COMPONENT jacks or HDMI and your TV supports progressive scanning technology (see the TV owner's manual if you don't know whether your TV is a progressive scan TV), slide the P.SCAN switch on the back of your Klipsch system to the ON position. If you put the P.SCAN switch in the ON position and your TV doesn't support progressive scan, you won't see a picture on the TV screen.

*Note: Until recently, TVs only had VIDEO INPUT jacks. Therefore, your TV might not carry the "IN" or "Input" label even though it is an input.*

*Note: If an HDMI (digital) input is used to connect a source (such as a cable or satellite box) to the CS-700, the TV must also be connected with an HDMI cable to preserve the digital signal. Also, if an analog signal is connected to the CS-700, the TV must also be connected with an analog signal. The CS-700 will not up-convert an analog signal to a digital signal.*

### Input and Output Jacks

Please see appendix I (page 28) for the basics on how input and output jacks work with your Klipsch system.



## STEP 5: Connect the Speakers

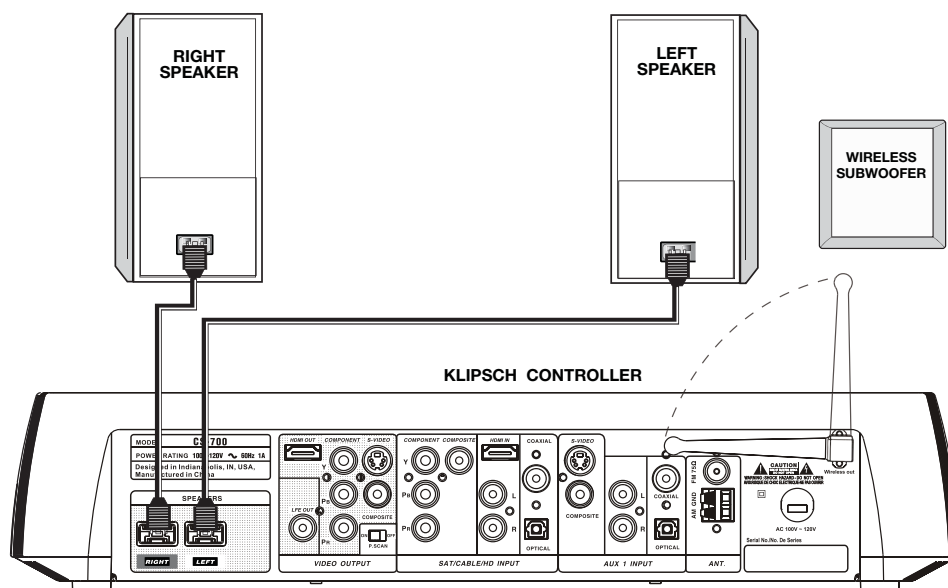

1. After you uncoil the speaker cable, connect one speaker to the RIGHT (Red) connector on the back of your Klipsch system. This speaker will be to your left when you are behind the system connecting, but it will be on the right when you are facing the system. You can connect either speaker to the LEFT or the RIGHT OUTPUT, you just need to place them properly.
2. Connect the other speaker to the LEFT (White) OUTPUT on the back of the Klipsch system. The speaker connected to the LEFT OUTPUT will be to your right when you are behind the system connecting, but it will be on the left when you are facing the system.
3. Rubber pads have been included in the Accessory box. These self adhesive pads can be applied to the bottom of the speakers.
4. The CS-700 wirelessly transmits the subwoofer signal from the A/V Center to the subwoofer. (If you wish to connect the subwoofer with a standard RCA cable, simply connect one end of the cable to the black "LFE" OUTPUT on the rear of the A/V Center and the other end to the "LFE" INPUT on the rear of the subwoofer. Cable not included.)
5. Plug the power cord into the subwoofer and an AC outlet and turn the subwoofer ON.
6. For best results, the antenna on the rear of the CS-700 A/V Center should be pointed up.

### Input and Output Jacks

Please see appendix I (page 28) for the basics on how input and output jacks work with your Klipsch system.

### Speaker Setup Considerations

- Front speakers typically sound best when their tweeters are at approximately ear height for seated listeners. If this isn't possible, it is sometimes beneficial to tilt the speaker down or up slightly so that it is aimed into the listening area.
- If possible, position the speakers the same distance apart as they are from the listening position.
- Speakers should be pointed straight forward. Do not place the speakers at an angle.
- If you are putting speakers in a cabinet, on a rack or a table, try to bring them out far enough so that they are at least flush with the cabinet's front edge.
- When practical, arrange each speaker so that it is at somewhat different distances from the floor, the wall behind it, and the wall beside it. It can also help to have the left and right front speakers at different distances from their nearest side walls. This staggering helps smooth the bass range. Each speaker can be set on its bottom or side. If you set them on the side and want to turn the Klipsch logo, carefully pull the logo forward, turn and release it.
- The subwoofer's output will increase as it is moved closer to walls, with maximum output when it is placed in a corner. If practical, always place the subwoofer near a wall. Additionally, a subwoofer will deliver the smoothest bass response when placed near a wall away from openings, such as doors.
- Naturally, there are exceptions to the rules, since no two rooms or systems are exactly alike. Experiment with positioning to get the best sound.

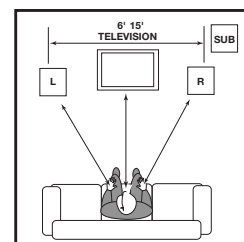

## STEP 6: Connect other components (OPTIONAL)

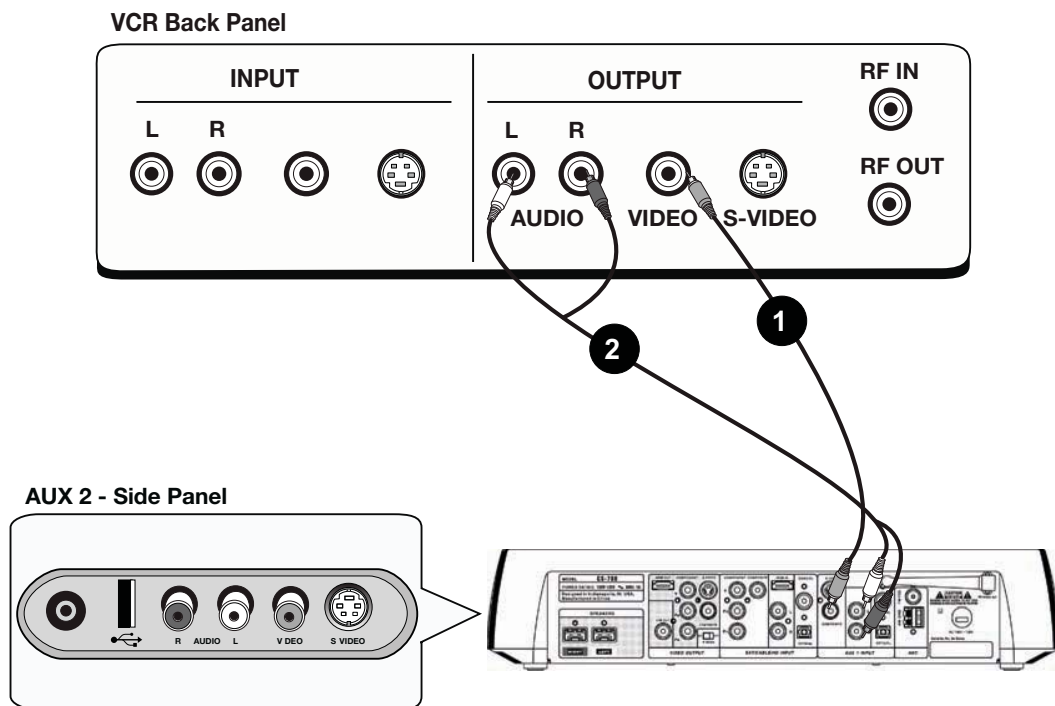

You can connect other components, such as a VCR, another recording device (like a hard-disk drive product or DVD Recorder), or a video game system to your Klipsch system using the AUXILIARY (AUX) INPUTS.

### Connecting a component to AUX 1 INPUT

1. From the component's output jacks, connect the best available video option to the Klipsch system's AUX 1 INPUT video jacks.
2. Do the same thing for the audio connection. Choose the best available connection from the component's AUDIO OUTPUT jacks, and connect appropriate cables. Connect the cable(s) to the Klipsch system's AUX 1 INPUT audio jacks.

### Connecting a component to AUX 2 INPUT (side)

The AUX 2 INPUT jacks on the side of your Klipsch system were designed for convenience when connecting temporary components, such as a video game system or a digital camera/camcorder.

1. From the component's output jacks, connect the best available video option.
2. Do the same thing for the audio connection. Choose the best available connection from the component's output jacks, and connect the appropriate cable.

### Connecting headphones to HEADPHONE OUTPUT

For private listening, connect compatible headphones to the HEADPHONE jack on the side of the Klipsch system.

### Connecting a device with USB to USB connector

Connect a device with USB OUTPUT to the Klipsch system's USB INPUT connector. This port is only for compatible USB flash memory drives. It is not suitable for direct connection to a computer.

*Note: This USB port is a part of the "DISC" Source, not Aux 2.*

### Input and Output Jacks

Please see appendix I (page 28) for the basics on how input and output jacks work with your Klipsch system.

### STEP 7: Connect AM and FM Antennas (supplied)

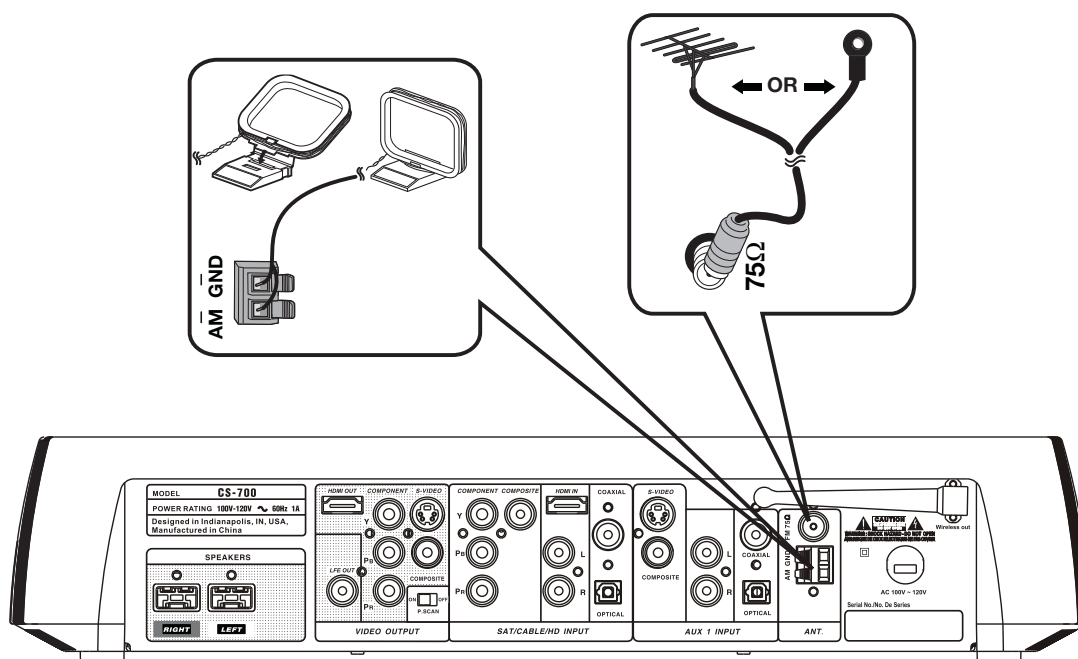

The back of your Klipsch System has jacks for the AM and FM antennas that were packed with your system. Unwind the wires for each antenna to provide the best reception. An outdoor antenna may be used in place of the supplied indoor antennas. To add an outdoor antenna, consult a qualified installer. Follow all safety instructions supplied with the antenna.

#### FM Antenna

Plug the FM antenna into the Klipsch system's FM (75Ω) jack in the section labeled ANT. On the back of your Klipsch system, spread out the antenna arms and move them around to establish optimum FM reception. Extend the antenna as much as possible.

Some cable TV providers make FM radio signals available through the cable service to your home. This connection is made to the external FM jack on the back of the Klipsch system. To connect to this service, contact your cable TV provider for assistance.

Make sure that the cable radio installation includes a TV/FM splitter so that only the FM radio band, not the cable TV band, is received by the Klipsch system. If necessary, contact your cable company.

#### AM Antenna

Plug the AM loop antenna into the AM GND jack in the section labeled ANT on the back of your Klipsch system. Place the antenna loop at least 20 inches (50 centimeters) away from your Klipsch system. To get optimum reception, you may need to experiment with the positioning of the loop antenna.

### STEP 8: Turn on the TV and the Klipsch System

1. Plug in the Klipsch system's power cord to an AC power outlet.
2. Turn on the Klipsch system (press the ON/OFF button on the front panel or on the remote control). You can also press DISC on the remote.
3. Turn on the TV and tune to the correct video input channel. This is the channel that corresponds to the input jack you used on the back of the TV to connect the Klipsch system. The name and how you access this video input channel varies for different TVs. Generally, you will press a button on the TV's remote control, such as SOURCE or INPUT or VID. See below if you can't find the correct input channel on your TV.

#### Set TV to the Right Channel

If you do not see a picture on your TV, check your TV's owner manual to see how you tune the TV to the correct channel. It won't be "Channel 3" but it's the same idea. You'll need to tune the TV to the "channel" that matches the input jacks on the TV you used to connect to the Klipsch system's output jacks (either COMPONENT, S-VIDEO, or COMPOSITE—which is regular VIDEO and color-coded yellow). Below are some ideas to try if you can't find the answer in the TV manual.

Button on TV Remote	Channel Number of TV			Button on TV
SOURCE	00	90	91	SOURCE
INPUT	92	93	VID 1	INPUT
LINE	VID	SVID	CMPNT	LINE
VIDEO				VIDEO
VID	You might have to press the TV's channel down button until you get to the correct video channel.			VID

## STEP 9: Complete the On-screen Setup

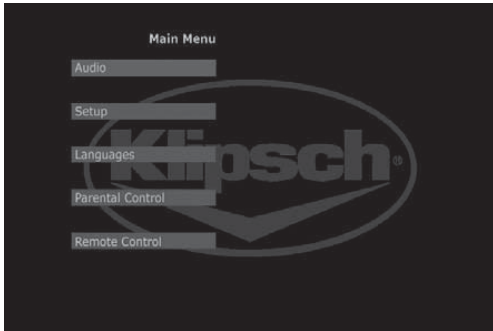

1. Press **MENU** on your Klipsch system remote control (the main menu appears).

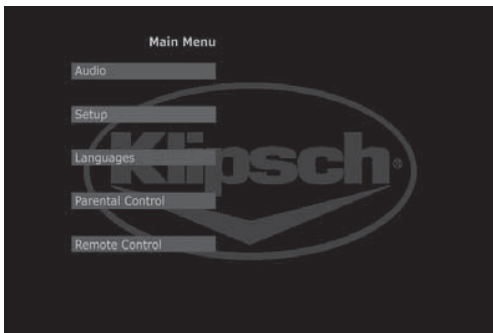

2. Press arrow down ▼ to highlight **Setup** and press **ENTER** (the **Setup** menu items appear).

Match the on-screen option with the cables that are connected to each of the jacks on your Klipsch system. This information tells the system what is connected to it, and which cables and jacks were used.

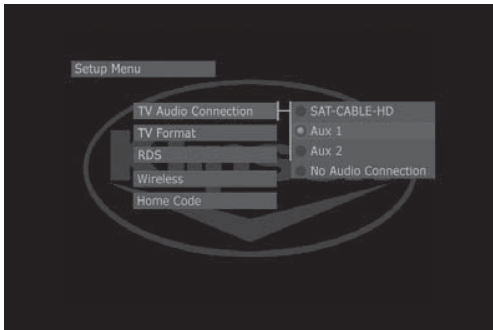

3. **TV Audio Connection:** If you made a TV Audio connection, use the arrow button to select where you connected the TV's AUDIO OUTPUT to the Klipsch system's AUDIO INPUT. Use the ▲ or ▼ arrow button to highlight the correct option and press **ENTER**.

**SAT/CABLE/HD:** Choose this option if you connected audio from the TV to one of the three AUDIO INPUT options in the SAT/CABLE/HD INPUT section on the back of the Klipsch system.

**AUX 1:** Choose this option if you connected audio from the TV to one of the audio options in the AUX 1 INPUT section on the back of the Klipsch system.

**AUX 2:** Choose this option if you connected the TV's audio to one of the AUX 2 INPUT audio options on the side of the Klipsch system.

**No Audio Connection:** Choose this option if you didn't connect the audio from the TV to the Klipsch system. You'll only hear audio from the Klipsch system when you're playing the radio or a disc, or through one of the components connected to the Klipsch System (e.g., VCR, DVD Recorder, mp3 player, etc.).

*Note: If you connected the audio from the TV's AUDIO OUTPUT jacks to the Klipsch system, you'll need to turn off your TV's internal speakers and may need to adjust the audio setting in the TV's menu system. Locate your TV manual to get specific instructions, as the procedures differ for different brands and types of televisions.*

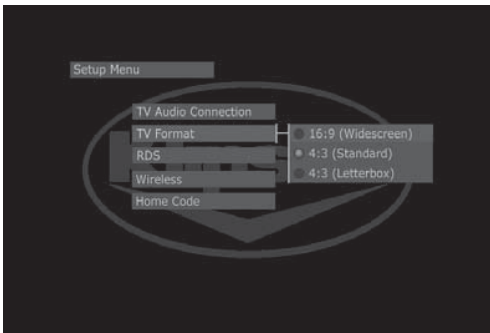

4. **TV Format:** TV Format lets you choose between a standard TV screen and a Widescreen option. The Widescreen option has an aspect ratio of 16:9. If your TV has a 4:3 aspect ratio, select either the Standard or Letterbox option depending on your preference.

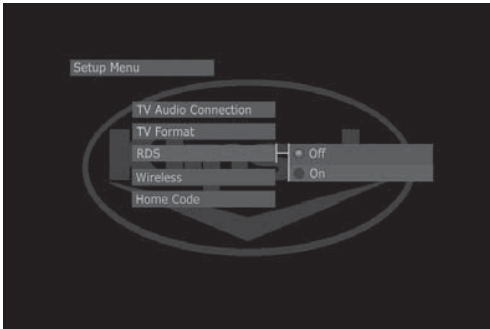

5. **RDS (Radio Data System):** RDS is the system that allows broadcasters to embed programming information in to the radio signal, such as the name of the artist or song. Your Klipsch system is RDS-enabled.

If you want to turn on RDS, choose **On** and press ENTER (the name of the radio station will appear on the Klipsch display).

*Note: On most U.S. radio stations, artist and title information will appear with the "Station ID."*

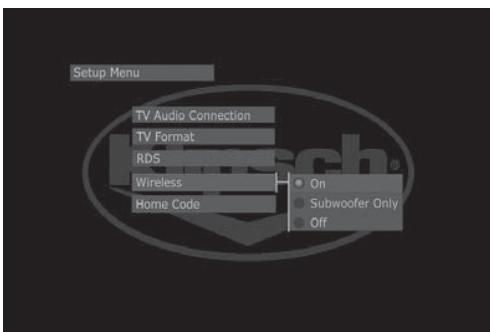

6. **WIRELESS:** Your Klipsch CS-700 system uses KlipschCast wireless technology to transmit the subwoofer signal from the A/V center to the subwoofer. The system is also capable if using KlipschCast to transmit any of its sources, on-board or auxiliary, throughout your home in CD quality. This signal can then be received and played by other Klipsch audio products using KlipschCast technology.

Selecting **Subwoofer Only** turns off the wireless broadcast to all KlipschCast components except the CS-700 subwoofer. For example, this might be done when viewing/listening to content on the CS-700 that you do not wish to broadcast to other KlipschCast components.

Selecting **All Off** will disable all wireless transmission including the subwoofer signal. This is primarily used for diagnostics.

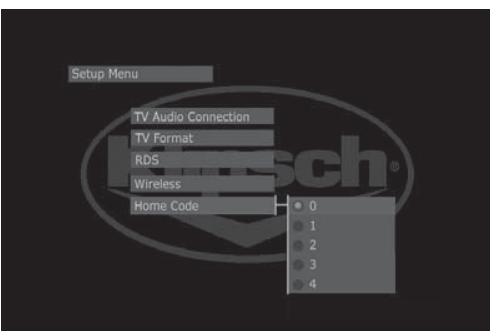

7. **HOME CODE:** The **Home Code** feature allows you to select a unique channel for all your KlipschCast components to keep your content private and unavailable to other nearby systems. The **Home Code** default is **0** for all KlipschCast components and does not need to be changed unless other nearby KlipschCast systems interfere. All KlipschCast components (including your subwoofer) in your multi-room system must be on the same home code to interact with one another. To check or change the home code on the CS-700, select **Home Code** in the **Setup Menu**. From here you can see the selected **Home Code** and change it if necessary.

To check or change the **Home Code** on your subwoofer, find the **Home Code** dial on the rear of the subwoofer. The dial can be rotated with a small flat blade screwdriver to select the desired number. If you change the **Home Code** you must turn the subwoofer off and on again to reset the **Home Code**. The cinema system and subwoofer must be on the same **Home Code** to communicate wirelessly.

## Your Klipsch Controller

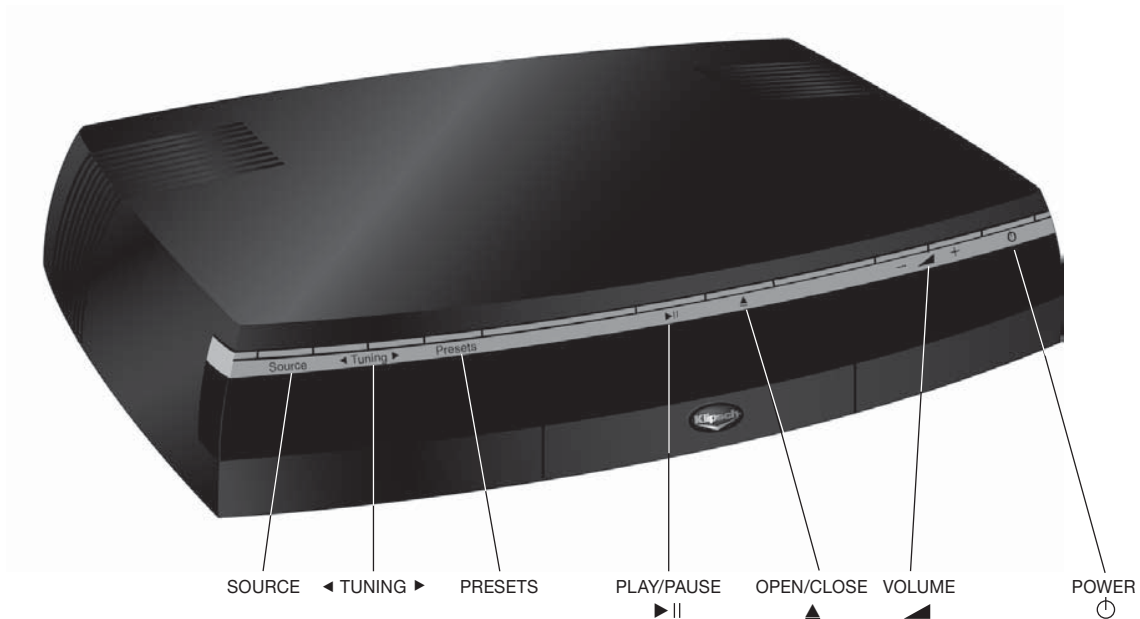

### Buttons

#### SOURCE

Chooses the function you want to use—radio, DVD/CD, watch TV, access any other components connected to your Klipsch system (VCR, video game system, etc.). Each time you press the SOURCE button, it goes to the next “Input” that corresponds to the component that’s connected to that input jack on the back of your Klipsch system.

#### PRESETS

When listening to the radio, this button moves to the next radio station that you programmed into the preset memory.

#### ▶|| PLAY/PAUSE

Plays discs in disc tray, and pauses playback when a disc is playing.

#### ▲ OPEN/CLOSE

Opens and closes the disc tray.

#### ⏻ POWER

Turns your Klipsch system on and off.

#### ▲ VOLUME

Adjusts the volume.

#### ◀ TUNING ▶

Changes radio station. Specific functionality of these buttons can be selected in the tuner setup menu.

### Display

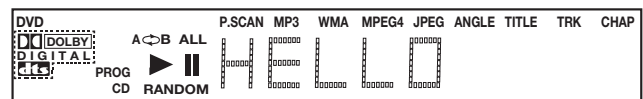

The display on the front of your Klipsch system provides playback information. The display illuminates each option that is active for the type of media you are playing. The numbers on the display let you know the track, title, and/or chapter number of the disc. Additionally, information from the radio’s RDS (Radio Data System), such as artist and track information, is displayed when you’ve tuned to the radio function. Below are explanations of display messages you may encounter that may not be covered in other parts of this manual.

### Dolby® Digital

The trademarked marketing name for Dolby Laboratories’ AC-3 codec. The common version contains six total channels of sound, with five channels for normal-range speakers (Right Front, Center, Left Front, Right Rear and Left Rear) and one channel for the subwoofer. The Dolby Digital format also supports Mono and Stereo. Your Klipsch system supports Dolby Digital with its 2.1 audio system design.

### DTS (Digital Theatre Systems)

A multi-channel surround sound format (rival of Dolby Digital). With DTS, the encoders and decoders support numerous channel combinations and stereo. DTS contains four-channel+LFE (Low Frequency Effects) audio tracks. Digital Theatre Systems was the name of the company that developed this format (currently referred to as DTS). Film director Steven Spielberg was one of the company’s initial investors. Spielberg films use the DTS audio format.

### P.SCAN (Progressive Scan)

Lights if the P.SCAN switch on the back of the Klipsch system is in the ON position.

## The Basics

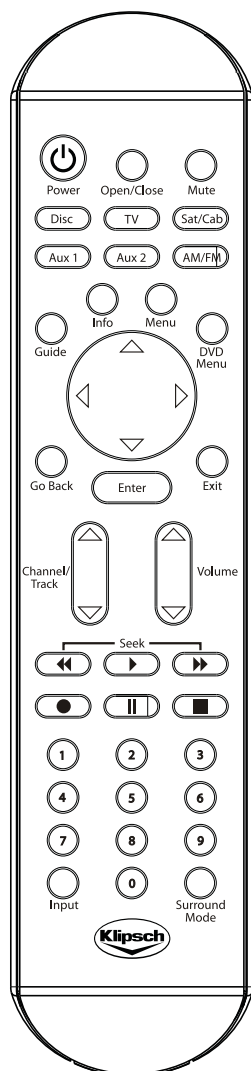

### Switching between media—TV, DVD, Radio, CDs, etc.

Your Klipsch system is the center of your entertainment room...now, you just need to understand how to get from one type of entertainment to another. To move to a different type of media, press the corresponding button on the remote control (DISC, AM/FM, SAT/CAB) or keep pressing SOURCE on the front of your Klipsch system to access the different options.

When you turn on your Klipsch system, it tunes to the last source you used. The front panel indicates what source is active.

<b>DISC</b>	DVD or CD
<b>AM/FM</b>	Radio
<b>SAT/CAB</b>	Watching TV from a set-top box (cable, satellite, HD receiver)
<b>AUX 1</b>	Component connected to AUX I INPUT jacks (e.g., TV or VCR)
<b>AUX 2</b>	Component connected to the jacks on the side of the unit
<b>TV</b>	Watching TV without a set-top box connected

### Progressive Scan TVs

On the back of your Klipsch CS-700 system, there is a progressive scan switch labeled P.SCAN. Progressive scan is a result of the digital TV transition—it is a process digital TVs can use to read and display broadcast signals. Progressive scan TVs display each pixel (picture element) of the signal consecutively line by line. All progressive scan TVs are digital, but not all digital TVs are progressive scan.

Some digital TVs only support the classic interlace display method that TVs have used since their inception. With interlace scanning, a TV draws every other line of the broadcast signal—first, the even numbered lines and then the odd numbered lines. This process happens so quickly it tricks your eye so it appears as though you're seeing the entire picture.



If your digital TV is progressive scan, turn the P.SCAN switch to ON. Additionally, you must use the COMPONENT VIDEO connection (Y, Pb, Pr) from the Klipsch system's VIDEO OUTPUT jacks to the progressive scan TV's COMPONENT VIDEO (Y, Pb, Pr) INPUT jacks in order for progressive scan to work correctly. See Step 4 on page 5 for detailed instructions.

*NOTE: If you put the P.SCAN switch in the ON position and your TV doesn't support progressive scan, you won't see a picture on the TV screen.*



## CHAPTER 2: REMOTE CONTROL

The universal remote control that came packed with your Klipsch system can be programmed to operate the basic functions of many other brands of audio and video components, such as TVs, satellite receivers, cable boxes, DVD players, and others. The design of the remote control groups the buttons to help you achieve better performance from your remote. In this section of the manual, you will learn the function of each button and how to program it to operate other brands of components. To use the remote control effectively, always aim it directly at the Klipsch controller.

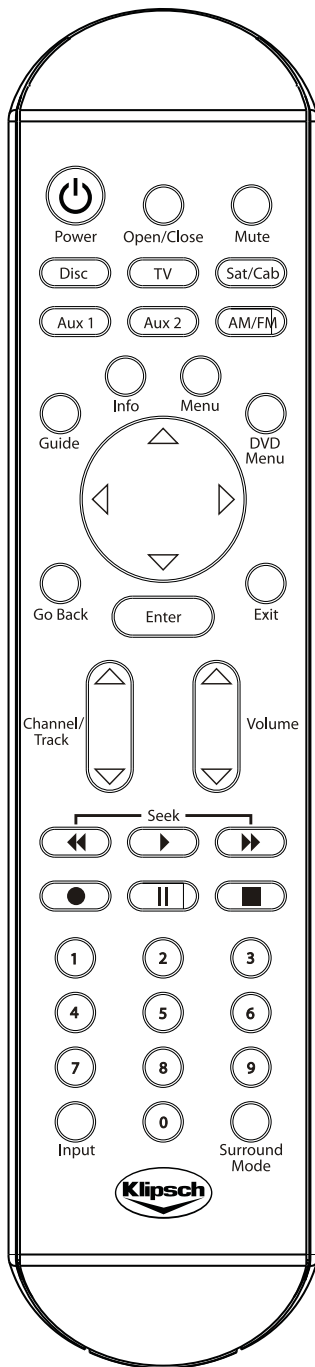

### Buttons

Descriptions of the buttons are arranged alphabetically to help you locate the information quickly.

**0-9** Use the number buttons for direct “channel” access in TV or SAT/CABLE mode. In addition, these numbers can be used to select or input information in the menus or information banners.

**ARROW BUTTONS** (△ ▽ ◀ ▶) Use the arrow buttons to highlight options and navigate through menu systems. The arrow buttons move the highlight in the corresponding direction of the arrow buttons.

**AM/FM** Selects the radio tuner and switches between AM and FM stations.

**AUX 1** Switches the Klipsch unit to AUX 1. When the **AUX 1** button is programmed, it operates the basic functions of the component connected to the AUX 1 INPUT jacks.

**AUX 2** Switches the Klipsch unit to AUX 2. When the **AUX 2** button is programmed, it operates the basic functions of the component connected to the AUX 2 INPUT (side panel) jacks.

**CHANNEL/TRACK** (Channel Up/Down) Selects the lower or higher station on the radio. If programmed properly, selects the lower or higher channel on a TV, satellite receiver, or cable system. Also skips tracks on CDs and chapters on DVDs.

**DISC** Places the remote in CD/DVD mode to operate the CD/DVD player.

**DVD MENU** Displays or removes the DVD disc’s menu.

**ENTER** Selects the highlighted option within a menu system.

**EXIT** Removes on-screen displays.

**FORWARD** (▶▶) Searches forward through a DVD, CD, mp3, and radio stations during playback (or video tape, recordable DVD, or camcorder if the remote is properly programmed).

**GO BACK** (◀◀) Returns to the previous menu in the menu system. When watching TV, satellite receiver or cable channels, tunes to the previous channel if the remote is programmed to operate those types of components.

**GUIDE** Displays the **DVD menu** when in DVD mode. During disc playback, displays the **title menu** if the disc has one and also removes the **title menu** and resumes playback. Displays the program guide in the TV or Satellite/Cable mode (if available) and if the remote is programmed to operate that component.

**INFO** Displays and removes the information banners for DVD, CD, and radio.



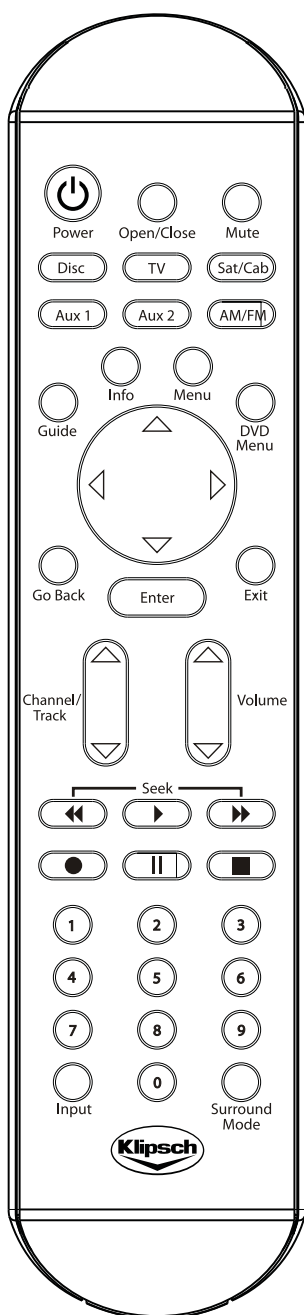

**INPUT** Accesses the individual input jacks on the Klipsch controller to see the signal of the component connected to the jacks.

**MENU** Displays the main menu of the selected component. In DISC or AM/FM mode, the **Klipsch menu** is displayed.



### Remote Control Batteries

If the batteries are removed from the remote control after you have programmed the component buttons, you might need to reprogram the buttons. The remote memory is only maintained for a short period of time.

- MUTE** Reduces the audio to a minimum level. Press again to restore the volume.
- OPEN/CLOSE** Opens and closes the disc drawer.
- POWER** Turns the Klipsch controller on and off and tunes it to the last selected input. If the remote is programmed to operate other components, the **POWER** button is used together with the component buttons (**AUX 1**, **TV**, **AUX 2**, and **SAT/CAB**) to turn the components on and off.
- PLAY**  Begins playback of disc (or video tape if the remote is properly programmed to operate a VCR).
- PAUSE**  Temporarily stops disc play (or video recording/playback, recordable DVD or compatible camcorder, if the remote is properly programmed to operate those types of components).
- RECORD**  When the remote is properly programmed, records a program on a recordable component, such as VCR, DVR, or RDV.
- REVERSE**  Searches backward through a DVD, CD, mp3, and radio stations during playback (or video tape, recordable DVD, or camcorder if the remote is properly programmed).
- SAT/CAB** (SATELLITE RECEIVER/CABLE) Switches the Klipsch unit to **SAT/CAB** INPUTS. When the **SAT/CAB** button is programmed, it operates the basic functions of the component connected to the **SAT/CABLE/HD INPUT** jacks.
- STOP**  Stops playback.
- SURROUND MODE** Toggles between the **OFF**, **ON** or **WIDE** options in surround audio.
- TV** Selects the TV for which the button was programmed and operates the basic functions of that TV.
- VOLUME** (VOLUME UP/DOWN) Controls the audio level in every mode except when using the menu system. Also, restores volume when **MUTE** has been activated.

### Programming Your Remote Control

Your remote control is a universal remote which means you can program it to operate other brands of electronic components, such as TVs, satellite receivers, cable boxes, VCRs, etc. Follow these steps to program your remote control.

1. Turn off the component to be programmed.
2. Look up the brand and code in the code list (located in the "More Information" section of this manual) or the "Remote Control" section of the on-screen menu system.
3. Press and hold the component button (**AUX 1**, **AUX 2**, **TV** or **SAT/CAB**) on the remote control for three (3) seconds, or until the LED goes out.
4. Release the component button and enter the first code for your brand and type of component.
5. If the code is accepted, the LED will flash 3 times.
6. Press the **POWER** button to see if the component turns on. If it doesn't, try another code from the list.

## CHAPTER 3: OPERATION



### Compatible Discs

- **DVDs**—DVD-R, DVD-RW, DVD+R, DVD+RW, and DVD-ROM.
- **CDs**—Audio CDs, CD-R, CD-RW, CD-ROM, and CDs that contain mp3 music files or JPEG (picture) files.
- **VCDs**—Video CDs contain video and audio, but hold less information than DVDs. VCDs are less common than DVDs. VCDs typically have lower quality video and audio than DVDs.
- **Super VCDs**—S-VCDs support MPEG-2 standard video and MPEG-1 audio. They typically hold about 70 minutes of content.

### Incompatible Discs

The Klipsch system does not support laserdiscs, CD-I, CD-ROM (computer only discs), and discs recorded using other broadcast standards, such as PAL, SECAM, DVD-RAM discs or pirated discs.

### Regional Coding

DVD Players and DVDs are coded by region. The region codes must match in order for the disc to play. The Klipsch system's DVD player is Region 1. You can only play Region 1 DVDs in this player.

### Playing a disc

1. Press **DISC** on the remote to put the Klipsch system in DVD mode or toggle the **SOURCE** button on top of the unit.
2. If the TV didn't turn on and tune to the correct **VIDEO INPUT** channel (you will see the Klipsch DVD screen), turn on your TV and tune the TV to the channel that matches how you connected the Klipsch system output jacks to the TV's input jacks (see page 5 for additional information).
3. Press **OPEN/CLOSE** (the disc tray opens).
4. Place a disc into the tray with the label facing up (double-sided discs have content on both sides, so you can load the disc with either side up). The label that is facing up is the content that plays.
5. Press **OPEN/CLOSE** or **PLAY** (the disc tray closes and your Klipsch system reads the contents of the disc).
6. What happens next depends upon the type of disc you put in the player and how it was formatted.
7. If the disc doesn't start playing automatically, follow instructions on the screen or press **PLAY**.

## DVD and VCD Playback Features

You can use the remote control to access various features during playback if the disc was formatted to support the features.

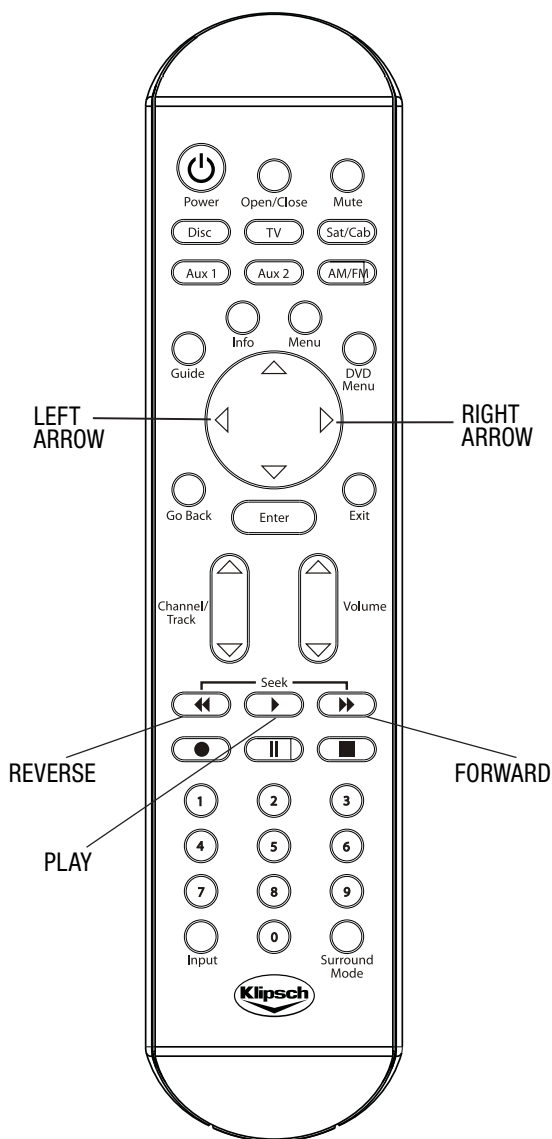

### Transport

To move forward or backward on the disc, simply press **FORWARD** or **REVERSE** during playback. Each time you press **FORWARD** or **REVERSE**, the speed will increase until the maximum search speed is reached. To resume playback, press **PLAY**.

To advance through the disc's chapters during playback, press the **CHANNEL ▲** button (the Info Banner appears with the Chapter selection highlighted). The **CHANNEL ▼** button takes you to the previous chapter.

To skip forward 10 seconds, press the **RIGHT ARROW** button. For an instant replay, which will skip backward 10 seconds, press the **LEFT ARROW** button.

In addition to using the remote control, you can use the Playback Info Banner to access many playback features. See page 17 for more information.

## Navigating Info Banners

Your Klipsch system is equipped with on-screen Info Banners that enable you to quickly access various playback features. The content of the banner changes depending upon the type of media you are playing, but the way you navigate the banners is the same.

- To access the Info Banner, press INFO while the disc is playing.
- To see the individual options of an info banner item, simply use the LEFT and RIGHT arrow buttons to highlight the option and press ENTER, or use the ▲ or ▼ arrows to select an option.
- There will be no Info Banners for mp3 or jpeg discs.

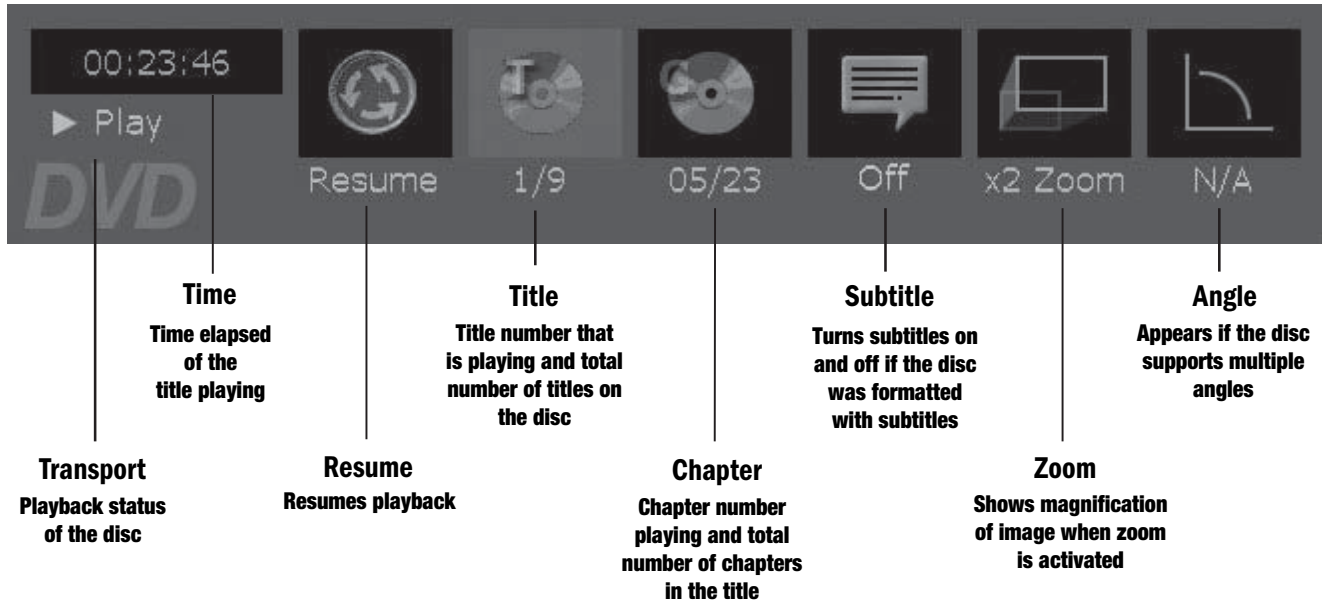

00:23:46

**TIME DISPLAY:** To use the time display as a search feature, highlight the icon and use the number buttons on the remote control to enter the time within the title you want to access and press ENTER. You must enter two digits for each field. For example, if you enter 0, 1, 2, 3, 1, 7 (01:23:17), playback will start one hour, 23 minutes, and 17 seconds into the title. Additionally, you can use the CHANNEL ▲ or the ▲ arrow button, CHANNEL ▼ or the ▼ arrow button to increase or decrease time one unit at time.



**RESUME:** To resume playback at the point where you paused playback, highlight the resume icon and press ENTER.



**TITLE:** If the disc has more than one title, you can go to another title by entering the number while the Title icon is highlighted. Additionally, to move to the next title, you can press CHANNEL ▲ or the ▲ arrow button. To go to the previous title, you can press CHANNEL ▼ or the ▼ arrow button.



**CHAPTER:** To access another chapter within the title that is playing, use the number buttons on the remote control while the Chapter icon is highlighted. Additionally, you can use the CHANNEL ▲ or the ▲ arrow button to move forward a chapter at a time or CHANNEL ▼ or the ▼ arrow button to go backward a chapter at a time.



**SUBTITLES (if available on disc):** To change the subtitles or turn off, highlight the Subtitle icon and use the ▼ arrow button to select and change the subtitle.



**ZOOM:** Shows the magnification chosen. To change, highlight the zoom icon and press ENTER.



**ANGLE:** If multiple angles are available for the title playing, this icon will indicate the number of angles and allow you to access other angles by pressing the ENTER button.

## Playing CDs

You'll get maximum sound while playing audio CDs in your Klipsch system. To access playback features, press INFO on the remote control during playback (the Info Banner appears).

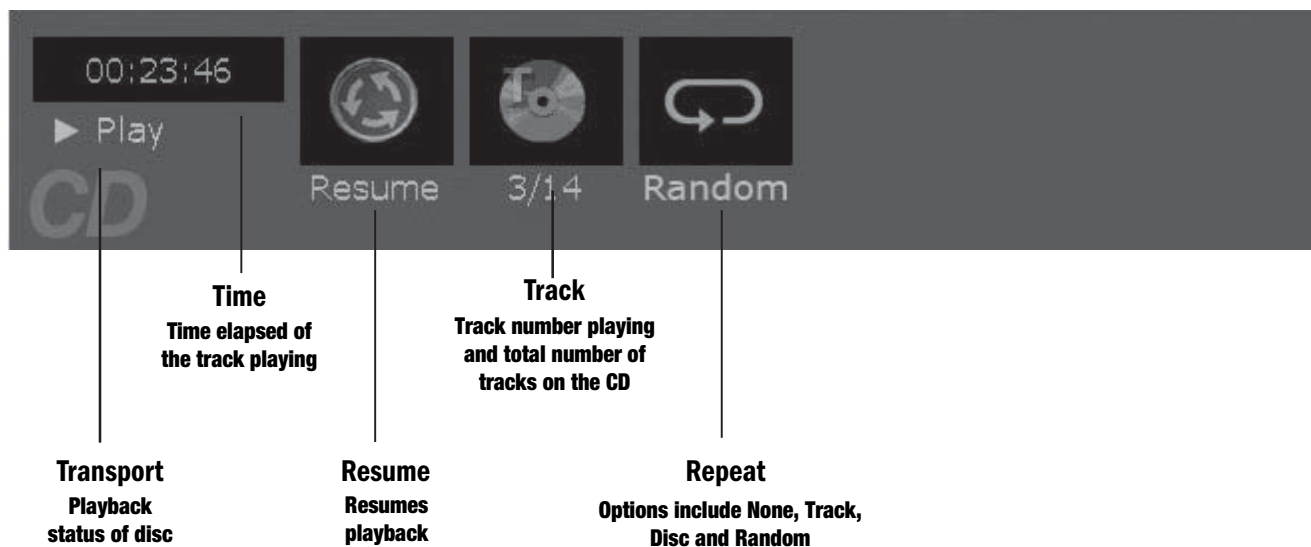

**00:23:46** **TIME DISPLAY:** To use the time display as a search feature, highlight the icon and use the number buttons on the remote control to enter the time within the track you want to access, and press **ENTER**. You must enter two digits for each field. For example, if you enter 0, 0, 0, 1, 2, 3 (00:01:23), playback will start one minute and 23 seconds into the track. Additionally, you can use the **CHANNEL ▲** or **▼** button to increase or decrease time one second at a time.



**RESUME:** To resume playback at the point where you paused playback, highlight the resume icon and press **ENTER**.



**TRACK:** Shows the track playing and the total number of tracks on the CD. To access another track, you can use the number buttons on the remote control to enter the track number. Additionally, to move to the next track, you can press the **CHANNEL ▲** or the **▲** arrow button. To move to the previous track, press **CHANNEL ▼** or the **▼** arrow button.



**REPEAT:** If you want to repeat playback of a Track or the Disc, or play the tracks in random order press **ENTER** with the Repeat icon highlighted. Press the **▼** arrow button to highlight the repeat option you want to use and press **ENTER**. To turn off repeat, select None and press **ENTER**.

## Playing CDs with mp3 or JPEG files

What you see on the TV screen when playing CDs with audio and picture files depends upon the way the discs were formatted and the file type used. Initially, the root menu will be displayed on the left side. Folders or files will be displayed on the right and can be selected. Highlight the desired folder or file from the right side and press ENTER. If a folder has been selected, its contents will be displayed in this area. If a file has been selected, it will play or be displayed on the screen. To navigate back up a level, select the root menu from the right side. ▲ and ▼ arrows keys are used to navigate through the list. If the disc doesn't play, consult the application you used to create the disc.

## Playing the Radio

When you are in the Tuner Mode, the remote control can be used to tune radio stations. Use the FORWARD and REVERSE or the CHANNEL ▲ or ▼ button to change the frequency.

### Setting up presets:

1. Tune to the station you would like. Press and hold the PRESET button for approximately three seconds and release. You will see a number that signals the next available preset on the display. Press the PRESET button again to stop the flashing and store the station.
2. To change a preset you already have, tune to the preset station you want to change and follow step 1.
3. There are twenty presets –10 FM and 10 AM.

## On-screen info banner

To access the radio info banner, press INFO on the remote control.

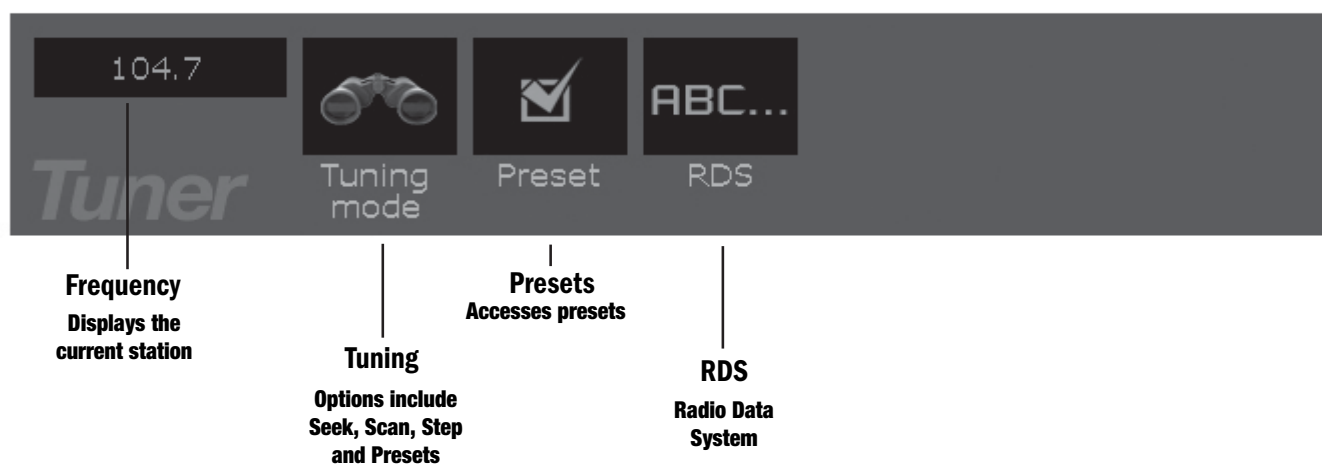

**TUNING MODE:** To access different ways to tune to various radio stations, press ENTER with the Tuning icon highlighted (the tuning options appear). Use the ▼ arrow button to highlight the option you want to use and press ENTER.

**SEEK:** Goes to the next available station and stays tuned to it.

**SCAN:** Previews stations throughout the frequency—plays for several seconds and then moves to the next station. To tune to a station during scan, press ENTER while it is playing.

**STEP:** Moves incrementally one frequency step at a time.



**PRESETS:** Shows you the station number for each of the presets available. Highlight the icon and press ENTER or ▼ arrow to see list and select.



**RDS:** RDS stands for Radio Data System and enables broadcasters to embed information in the signal. You can choose to turn this feature on or off. Highlight this icon and press ENTER or press the down ▼ arrow to see list.



## CHAPTER 4: MENU SYSTEM

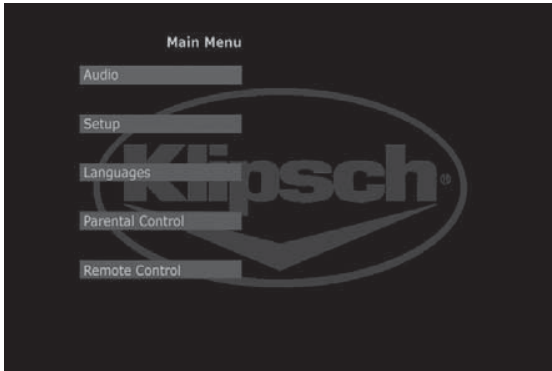

### On-Screen Menu System

Your Klipsch CS-700 System contains on-screen menus that let you personalize settings to get the most out of your home theater experience.

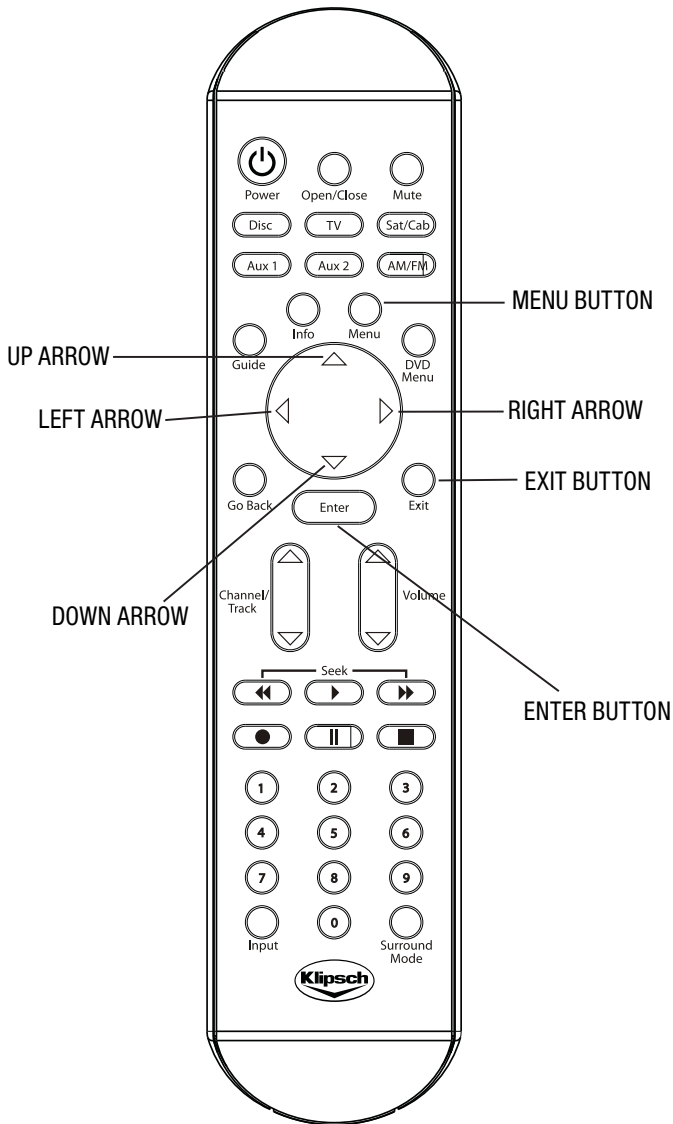

### Navigating Menus

To access the menu system, press MENU (the main menu appears).

Use the arrow buttons to move the direction you want to go. You'll notice the menu is highlighted to let you know where you are.

When a menu item is highlighted, press ENTER to see the submenus or to activate the option that is highlighted.

## On-Screen Menus

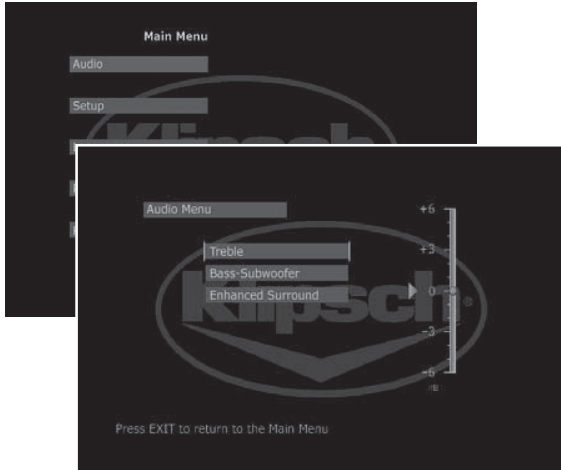

### Audio

**Treble:** Use the ▲ and ▼ arrow buttons to increase or decrease the amount of high frequency sound.

**Bass-Subwoofer:** Use the ▲ and ▼ arrow buttons to increase or decrease the amount of low frequency sound.

**Enhanced Surround:** Choose the setting that is most desirable to you. Use the arrow button to highlight **ON**, **OFF** or **WIDE** and press ENTER.



### Setup

The **Setup** menu is described in Chapter 1. If you add components to your system or change how they are connected, you may need to access the **Setup** menu to tell your Klipsch system what is where and how it is connected. Go to page 9 for detailed instructions.

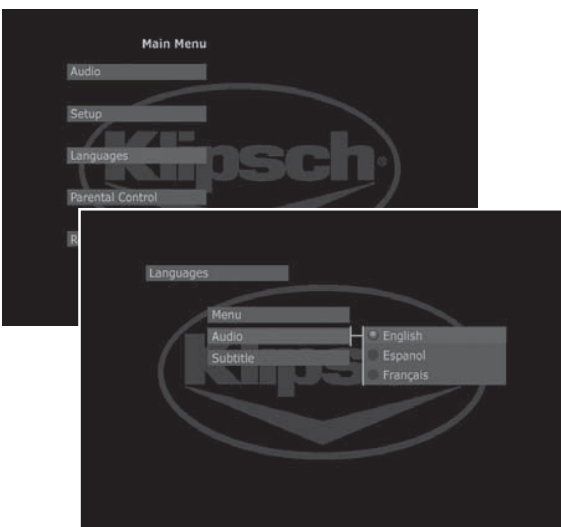

### Languages

**Menu:** Choose the language of the on-screen menus.

**Audio:** For DVDs, you can choose your primary language. If the DVD was formatted with that language, the DVD will play in the language you select. The default is English.

**Subtitle:** For DVDs, you can change the language setting for subtitles. If the DVD was formatted with subtitles in the language chosen in this menu, the subtitles will appear in that language. Turn on subtitles via the Info Banner during playback (page 17).

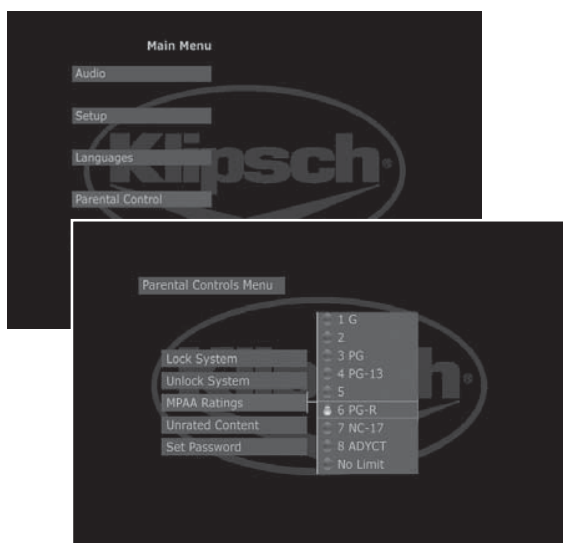

## Parental Control

The **Parental Control** menu lets you password-protect DVDs by using the MPA A (Motion Pictures Association of America) rating system to tell the Klipsch system which ratings require a password in order to play the DVD.

**Lock System/Unlock System:** Locking the system puts the ratings limit you have selected into effect. Use the digits buttons to enter a four-digit password.

**MPAA Ratings:** Use the ▲ and ▼ arrow buttons on the remote to select to the highest rating you find acceptable. Press ENTER.

**Unrated Content:** Some discs contain movies that don't have a rating assigned to them. Sometimes, movies you might find the most explicit are unrated. Also, much of the new content on DVDs, such as director's cuts, interviews with actors, etc., is unrated. In this menu, tell the Klipsch system how you want unrated content to be handled. Choose **Lock Unrated Content** if you want unrated content to be password protected.

**Set Password:** Use the number buttons on the remote control to enter the password that will be required for DVD content that is rated above the level you have set as acceptable in the **MPAA Ratings** menu.

*Note: It's a good idea to write down your password and keep it in a safe place.*

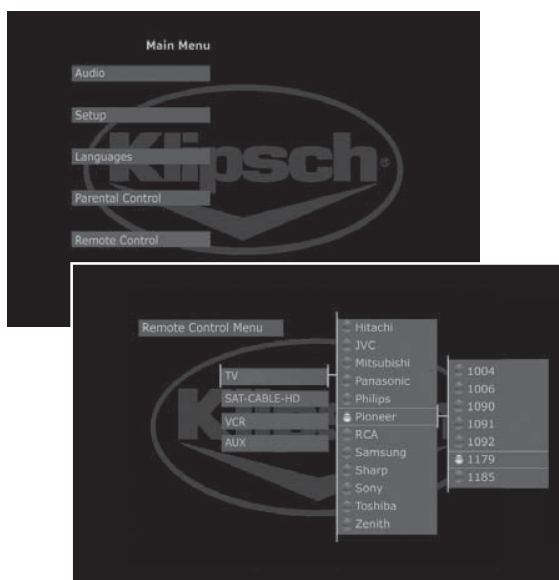

## Remote Control

The easiest way to control your home theater experience is to take the time to program the remote control to operate your TV, set-top box or any other components you have connected to your Klipsch system. Instructions for programming the remote control are in Chapter 2. To program the remote control, you have to find the code that matches the component you have. The codes are in Chapter 6, but are also provided in this menu.

**TV:** In order for your Klipsch remote control to operate your TV, follow the instructions in Chapter 2. To enter the code for your TV, access the **Remote Control** menu. With **TV** highlighted, press ENTER.

**SAT-CABLE-HD:** This menu has codes for satellite receivers, cable boxes, and HD receivers. Use the codes in this menu to program your remote control to operate the type of set-top box you connected to your Klipsch system.

**AUX 1:** Use codes to program the remote control to operate a connected component, preferably the component you have connected to the AUX 1 jacks on the back of your Klipsch system.

**AUX 2:** Use codes to program the remote control to operate a connected component, preferably the component you have connected to the AUX 2 jacks on the side of your Klipsch system.

## CHAPTER 5: TROUBLESHOOTING

Trying to find the solution to a problem with your equipment can be very frustrating. The symptoms and solutions in this section will hopefully assist you in finding the correct answers. If you have additional questions that this manual cannot answer, please contact your nearest Klipsch dealer or call 1-800-KLIPSCH.

### General problems

- No power—make sure you use an outlet that is not controlled by a wall switch.
- No power—make sure you've plugged the unit into a working outlet or the power strip is turned on.
- Menu is displayed in a foreign language—check **Languages** in the menu system to make sure the language that you want is selected.
- Screen saver appears on TV—press any button to remove the screen saver from the TV screen.
- Disc tray doesn't open—try unplugging the power cord and plugging it back in. Press and hold **STOP** for approximately 3 seconds to open the tray.
- Disc won't eject—disc cannot be ejected when the player is reading the disc. Wait a few seconds before ejecting the disc.

### Video problems

- Make sure the TV and Klipsch system are turned on.
- Make sure the Klipsch system is in DVD mode (press **DISC** on the remote control).
- Make sure the TV is tuned to the VIDEO INPUT Channel that matches the input jack(s) you used to connect the TV to the Klipsch system (see page 5).
- Make sure the cables are attached securely (check your connections on page 5). You must connect Klipsch output jacks to a set of the TV's input jacks.
- Check the **P.SCAN** switch on the back of the Klipsch system. Make sure it is in the **OFF** position unless you are certain your TV supports progressive scan. The components must be connected via the Y, Pb, Pr jacks to use **P.SCAN**. See page 12 for additional information.
- Check the settings in the **Parental Control** menu.
- HI DEF COMPONENT VIDEO INPUT Y, Pb, Pr must have a corresponding HI DEF COMPONENT VIDEO OUTPUT.
- Digital HDMI COMPONENT VIDEO INPUT must have a corresponding Digital HDMI COMPONENT VIDEO OUTPUT.

### Audio problems

- Make sure the cables are attached correctly, and that you've connected the appropriate cable to the appropriate jack (see page 28 for information about different audio options).
- Refer to your TV's owner manual to find out the procedures to set up your TV for a home theater system. With most TVs, you'll need to turn off the TV's internal speakers via the TV menu or a switch on the back of the TV. Additionally, you may need to change the Fixed or Variable setting.
- Check the settings in the Klipsch system's **Setup** menu, specifically the **TV Audio Connection** submenu. Make sure your selection matches the Klipsch system input jack you used to connect the audio originating from the TV or set-top box.

- If there is noise when the TV is turned on, the speakers may be too close to the audio system. See page 6 for more information.
- Make sure the **MUTE** button on the remote control has not been activated.
- Make sure the disc is not bad, damaged or dirty.
- Check the speaker cable connections.
- Check the options selected in the **Audio** menu.

### Remote Control problems

- Make sure you have selected the correct component button placing the remote in that mode to operate the component.
- Check batteries and replace them if they are weak.
- Make sure batteries are inserted correctly with the polarities matching.
- If you programmed your remote to operate a specific component, you might need to re-program it.
- Make sure there are no obstructions between the remote and the component you're trying to operate.

### Playback problems

- If the disc isn't playing, make sure the type of disc matches those listed in Chapter 3. If you're trying to play a DVD, make sure it is inserted with the label side up and it is coded for Region 1.
- If the disc starts to play, but stops immediately, you might need to clean the disc or check for condensation in the player. If condensation has formed in the player, allow it to dry.
- If the picture is distorted, fuzzy or jumps, try another disc as the disc might be damaged.

### Radio problems

- If the incoming signal is weak, distorted, or noisy, you might need to connect an outside FM antenna or change the direction of the antenna.

### General Wireless problems

- Make sure you have the wireless turned **ON** in the **Wireless menu** (within the setup menu).
- Make sure all KlipschCast components are set to the same home code number.

If your wireless broadcast to other KlipschCast component (other than the subwoofer) is interrupted for long periods of time or has static:

- You may have moved the KlipschCast component beyond its extended range. Try locating it closer to the CS-700 system.
- Check to make sure you have the proper source selected.
- The CS-700 system can only decode one digital multi channel signal at a time. You cannot decode one digital signal for local viewing/listening and a second for wireless transmission. Wireless transmission occurs in two-channel mode therefore it is recommended that you change the audio output of the source you wish to transmit to analog (R/L) stereo. This will allow you to use the decoder in the CS-700 for the locally viewed/heard source and wirelessly distribute the second signal to all KlipschCast listeners.

## CHAPTER 6: CARE AND MAINTENANCE

### Klipsch System

- If your unit has been stored in a cool place for any length of time, during a journey for example, wait for about 2 hours before using it.
- Keep the equipment away from sources of heat, such as a stove or radiator.
- Avoid blocking the ventilation openings on the unit to prevent overheating.
- This unit is designed for continuous use. Switching off the unit places it in standby mode, but does not disconnect it from the outlet power.
- If you notice any burning or smoke, disconnect the unit immediately to avoid any damage to you, the house, and/or the unit.
- If an object or liquid enters the unit, unplug it immediately and have it checked by an authorized dealer.
- Do not attempt to look inside the unit through the disc tray opening or any other opening. Invisible laser radiation when open. Avoid exposure to beam. Class 1 laser product. This system must be opened only by qualified technicians to prevent accidents caused by the laser beam.
- This unit is for domestic use only and must not be used for industrial purposes.
- Total or partial copying of recordings protected by copyright legislation, without the explicit permission of the holder of the rights, contravenes current legislation.
- Copying or downloading music files for sale or any other business purpose constitutes or could constitute a violation of copyright law.

### Cleaning

- Use a soft, dry, clean cloth when cleaning the unit. Regularly dust all vents.
- Do not use solvents, abrasive or alcohol-based products when cleaning your system as it might damage the unit.

### Handling and Caring for Discs

- Handle your discs with care. DO NOT touch a disc's surface. Hold it by the edge, or by one edge and the center hole.
- Use a soft clean cloth to wipe a disc. Wipe from the inner edge toward the outer edge. DO NOT WIPE IN A CIRCULAR MOTION.
- Insert the disc with the label facing up (for a single-sided disc).
- Place the disc properly into the tray. Never place two discs or more in the tray.
- Always keep discs in their cases and store the cases vertically.
- DO NOT store discs in direct sunlight or locations with high temperatures or high humidity, or extremely low temperatures.
- DO NOT write on a disc or put labels or tape on the label surfaces.
- DO NOT scratch discs.
- DO NOT move the unit when a disc is being played.
- DO NOT use record cleaning sprays, anti-static liquids, benzene thinner, or other solvents for cleaning discs. They can damage the disc surface.

## Remote Control Code Lists

Audio-Digital Tape  
(AUX 1 / AUX 2 buttons)  
Sony ..... 5043

Cable  
(SAT-CAB / AUX 1 / AUX 2 Buttons)

ABC ..... 4000, 4001, 4002, 4030  
Archer ..... 4007  
Cableview ..... 4003  
Contec ..... 4034  
Eastern ..... 4035  
GE ..... 4000  
Gemini ..... 4012, 4013  
General Instruments ..... 4000,  
..... 4032  
Hamlin ..... 4036, 4037, 4038,  
..... 4040, 4044  
Hitachi ..... 4000  
Jerrold ..... 4000, 4012, 4015,  
..... 4016, 4026, 4030, 4032  
Motorola ..... 4031  
Movie Time ..... 4039  
NEC ..... 4033  
NSC ..... 4039  
Oak ..... 4034, 4041  
Panasonic ..... 4027, 4029  
Philips ..... 4009, 4010, 4011,  
..... 4013, 4018, 4019, 4020  
Pioneer ..... 4021, 4022  
Proscan ..... 4000  
RCA ..... 4003, 4029, 4032  
Samsung ..... 4022  
Scientific Atlanta ..... 4002, 4023,  
..... 4024, 4025  
Signature ..... 4000  
Sprucer ..... 4029  
Standard Component ..... 4042,  
..... 4043  
Starcom ..... 4012, 4030  
Stargate ..... 4012  
Tocom ..... 4001, 4015  
United Cable ..... 4030  
Universal ..... 4004, 4007  
View Star ..... 4034, 4039  
Zenith ..... 4028

Satellite Receiver  
(SAT-CAB / AUX 1 / AUX 2 Buttons)

Alphastar ..... 3028  
BSB ..... 3003, 3005, 3013  
Chaparral ..... 3024  
DirecTV ..... 3001  
Drake ..... 3027  
Echostar ..... 3026  
Express Vu ..... 3030  
Fujitsu ..... 3022  
GE ..... 3004, 3032, 3033, 3046  
General Instruments ..... 3018,  
..... 3019  
Hitachi ..... 3023, 3045  
Hughes ..... 3023, 3043, 3047  
Janel ..... 3022  
JVC ..... 3015  
Mitsubishi ..... 3002  
Panasonic ..... 3005, 3011, 3036  
Phillips ..... 3000  
Proscan ..... 3032, 3033, 3038,  
..... 3044  
Radio Shack ..... 3018, 3019  
RCA ..... 3032, 3033, 3037,  
..... 3039  
Realistic ..... 3014  
Samsung ..... 3006, 3028  
Sony ..... 3007, 3040, 3042  
Star Choice ..... 3031

Star Trak ..... 3021  
STS ..... 3020  
SuperDish ..... 3023, 3025  
Toshiba ..... 3008, 3029  
Uniden ..... 3016, 3017, 3041  
Zenith ..... 3009, 3022

Satellite Receiver/Recorder  
(SAT-CAB / AUX 1 / AUX 2 Buttons)

Philips ..... 3012  
RCA ..... 3010  
SONY ..... 3035  
Zenith ..... 3013

TV  
(TV / AUX 1 / AUX 2 Buttons)

Action ..... 0108  
Admiral ..... 0071, 0093, 0099,  
..... 0118, 0127, 0130, 0131  
Advent ..... 0147  
Aiko ..... 0079  
Aiwa ..... 0047  
Akai ..... 0104, 0105, 0123  
AOC ..... 0073, 0074, 0075, 0104,  
..... 0112, 0117, 0134, 0140  
Apex ..... 0000, 0001, 0015, 0016  
Audiovox ..... 0082, 0108, 0140,  
..... 0144  
Bell & Howell ..... 0071, 0084,  
..... 0118, 0131  
Benq ..... 0051  
Broksonic ..... 0037, 0038, 0104,  
..... 0106, 0118, 0138, 0146  
Carver ..... 0153  
CCE ..... 0118  
Centurion ..... 0077  
Citek ..... 0143  
Citizen ..... 0073, 0075, 0079,  
..... 0082, 0089, 0092, 0138  
Classic ..... 0104, 0123  
ColorTyme ..... 0073, 0075,  
..... 0105, 0116  
..... 0118, 0125, 0127, 0139  
Contec/Cony ..... 0078, 0082,  
..... 0106, 0108  
Craig ..... 0082, 0106, 0108,  
..... 0114, 0119, 0125, 0138  
Crosley ..... 0118, 0153  
Crown ..... 0082, 0087, 0119,  
..... 0134  
CTX ..... 0056  
Curtis Mathes ..... 0070, 0073,  
..... 0075, 0084, 0089, 0092,  
..... 0102, 0105, 0112, 0117,  
..... 0118, 0125, 0127, 0134,  
..... 0135, 0148, 0153, 0155  
Daewoo ..... 0073, 0074, 0075,  
..... 0079, 0092, 0104, 0110,  
..... 0112, 0117, 0134, 0135,  
..... 0140, 0144  
Dallan ..... 0006, 0014, 0016,  
..... 0136  
Daytron ..... 0073, 0075, 0092,  
..... 0114, 0117, 0134, 0140  
Denon ..... 0145  
Dumont ..... 0073, 0091  
Electrohome ..... 0072, 0073,  
..... 0075, 0080, 0104, 0105,  
..... 0117, 0134  
Emerson ..... 0073, 0075, 0078,  
..... 0081, 0082, 0083, 0084,  
..... 0092, 0096, 0103, 0104,  
..... 0105, 0106, 0108, 0114,  
..... 0117, 0119, 0125, 0129,  
..... 0131, 0134, 0139, 0144,

..... 0146  
Envision ..... 0073, 0075, 0105,  
..... 0112  
Fisher ..... 0052, 0084,  
..... 0115, 0123, 0124, 0133  
Fujitsu ..... 0083  
Funai ..... 0082, 0083, 0106, 0108  
GE ..... 0009, 0066, 0067, 0070,  
..... 0072, 0073, 0075, 0085,  
..... 0086, 0104, 0106, 0110,  
..... 0113, 0116, 0117, 0125,  
..... 0126, 0127, 0128, 0134,  
..... 0144, 0149, 0154, 0155  
Goldstar ..... 0073, 0074, 0075,  
..... 0078, 0080, 0092, 0104,  
..... 0105, 0109, 0112, 0117,  
..... 0134, 0135, 0137  
Gradiente ..... 0105, 0122, 0123  
Granada ..... 0134  
Grundig ..... 0126, 0134  
Harmon Kardon ..... 0104  
Hisense ..... 0151  
Hitachi ..... 0041, 0042, 0058,  
0059, ..... 0068, 0073, 0075, 0078,  
..... 0101, 0117, 0126, 0127,  
..... 0131, 0134, 0140, 0145  
Infinity ..... 0087, 0153  
Inovision ..... 0009, 0076, 0144  
Janel ..... 0094  
JBL ..... 0087, 0153  
JCPenney ..... 0070, 0073, 0074,  
..... 0075, 0085, 0086, 0089,  
..... 0092, 0104, 0112, 0113,  
..... 0125, 0126, 0127, 0134,  
..... 0149, 0155  
Jensen ..... 0073, 0075, 0105,  
..... 0129  
JVC ..... 0007, 0010, 0012, 0031,  
..... 0036, 0078, 0086, 0103,  
..... 0122, 0125, 0126  
Kawasho ..... 0073, 0075,  
..... 0112, 0123  
Kenwood ..... 0073, 0075, 0080,  
..... 0104, 0105, 0112,  
..... 0116, 0139  
Kloss Novabeam ..... 0082, 0094,  
..... 0110  
KTV ..... 0082, 0092, 0106,  
..... 0108, 0112, 0117, 0134  
LG ..... 0074  
Loewe ..... 0087  
Logik ..... 0071, 0142  
Luxman ..... 0073, 0075  
LXI ..... 0070, 0075, 0084,  
..... 0087, 0104, 0118, 0127,  
..... 0149, 0153, 0155  
Magnasonic ..... 0104, 0105,  
..... 0131, 0140  
Magnavox ..... 0017, 0073, 0075,  
..... 0080, 0087, 0104, 0105,  
..... 0112, 0114, 117, 118,  
..... 0119, 0126, 0131, 0153  
Majestic ..... 0071  
Marantz ..... 0073, 0075, 0087,  
..... 0105, 0112, 0116, 0117,  
..... 0118, 0153  
Megatron ..... 0075  
Memorex ..... 0071, 0074,  
..... 0075, 0084, 0104  
MGA ..... 0073, 0074, 0075,  
..... 0080, 0105  
Mitsubishi ..... 0049, 0073, 0074,  
..... 0075, 0080, 0104, 0105,  
..... 0112, 0117, 0134  
Motorola ..... 0072, 0093

MTC ..... 0073, 0074, 0075, 0089,  
..... 0104, 0112, 0118, 0125, 0140  
Multitech ..... 0082  
Multivision ..... 0088  
NAD ..... 0075, 0101  
NEC ..... 0072, 0073, 0074, 0075,  
..... 0105, 0112, 0116, 0117, 0139  
Nikko ..... 0075, 0079, 0140  
Optimus ..... 0101  
Optonica ..... 0093  
Orion ..... 0096, 0130, 0146  
Panasonic ..... 0003, 0011, 0023,  
..... 0032, 0033, 0034, 0072,  
..... 0086, 0087, 0108, 0110,  
..... 0113, 0126, 0127, 0128,  
..... 0140  
Philco ..... 0072, 0073, 0074  
..... 0075, 0078, 0080, 0087,  
..... 0104, 0105, 0112,  
..... 0114, 0117, 0118, 0119,  
..... 0131, 0140, 1045, 0153  
Philips ..... 0004, 0005, 0029,  
..... 0030, 0072, 0073, 0078,  
..... 0080, 0087, 0118, 0153  
Pioneer ..... 0045, 0073, 0075,  
..... 0101, 0110, 0111, 0116,  
..... 0117  
Portland ..... 0073, 0074, 0075,  
..... 0079, 0092, 0104, 0112,  
..... 0117, 0134, 0135  
Prima ..... 0135, 0142, 0152  
Prism ..... 0086  
Proscan ..... 0070, 0127,  
..... 0149, 0154, 0155  
Proton ..... 0073, 0075, 0078,  
..... 0104, 0105, 0117, 0119,  
..... 0127, 0134, 0138  
Quasar ..... 0053, 0063, 0064,  
..... 0072, 0086, 0110, 0114,  
..... 0126, 0128  
Radio Shack ..... 0084, 0106,  
..... 0108, 0110, 0118, 0120,  
..... 0124, 0127, 0132, 0134,  
..... 0155  
Radio Shack/Realistic ..... 0070,  
..... 0073, 0075, 0078, 0082  
..... 0084, 0092  
RCA ..... 0008, 0060, 0065,  
..... 0070, 0072, 0073,  
..... 0074, 0075, 0080, 0102,  
..... 0106, 0110, 0111, 0113,  
..... 0116, 0117, 0125, 0127,  
..... 0128, 0134, 0148, 0149,  
..... 0154, 0155  
Runco ..... 0091  
Sampo ..... 0039, 0073, 0075,  
..... 0092, 0110, 0112, 0117  
Samsung ..... 0043, 0048, 0054,  
..... 0057, 0062, 0073, 0074,  
..... 0075, 0078, 0080, 0092,  
..... 0097, 0104, 0112, 0117,  
..... 0118, 0125, 0131, 0134,  
..... 0139  
Sansui ..... 0022, 0096, 0120  
Sanyo ..... 0073, 0084, 0115,  
..... 0124  
Scott ..... 0073, 0075, 0078,  
..... 0082, 0083, 0106, 0108,  
..... 0117, 0130, 0134  
Sears ..... 0070, 0073, 0075  
..... 0080, 0083, 0084, 0095,  
..... 0104, 0106, 0115, 0118,  
..... 0124, 0127, 0133, 0134,  
..... 0149, 0153, 0155  
Sharp ..... 0013, 0028, 0035,

**Remote Control Code Lists (continued)**

.....	0073, 0075, 0078, 0092,
.....	0093, 0120, 0131, 0132,
.....	0134, 0139, 0141
Signature.....	0071
Signature 2000.....	0115, 0132
Sony.....	0002, 0018, 0026, 0098,
.....	0100, 0121, 0123, 0134
Soundesign.....	0073, 0075,
.....	0082, 0083, 0104, 0106,
.....	0117, 0119, 0129
Starlite.....	0082
Sylvania.....	0044, 0046, 0069,
.....	0073, 0075, 0080, 0087,
.....	0104, 0105, 0112, 0114,
.....	0117, 0118, 0119, 0140, 0153
Symphonic.....	0081, 0082,
.....	0095, 0108
Tandy.....	0093, 0118
Tatung.....	0072, 0110, 0138
Technics.....	0086, 0126, 0128
Techwood.....	0073, 0075,
.....	0086, 0105, 0118
Teknika.....	0071, 0073, 0074,
.....	0075, 0078, 0079, 0082,
.....	0083, 0089, 0092, 0106,
.....	0108, 0112, 0116, 0117
.....	0119, 0134, 0137, 0140
.....	0143, 0153
Telecaption.....	0090
Telefunken.....	0139
Toshiba.....	0006, 0019, 0021,
.....	0024, 0025, 0027, 0084,
.....	0089, 0090, 0115, 0125,
.....	0133, 0150
Ultra.....	0140
Uniden.....	0121
Universal.....	0085
Video Concepts.....	0106
Vidikron.....	0118, 0153
Vistek.....	0040, 0048
Wards.....	0070, 0071, 0073,
.....	0074, 0075, 0080, 0081,
.....	0083, 0085, 0087,
.....	0104, 0112, 0113, 0117,
.....	0118, 0119, 0120, 0125,
.....	0127, 0131, 0153, 0155
White Westinghouse.....	0104,
.....	0112, 0134, 0135,
.....	0140, 0144
Yamaha.....	0073, 0074, 0075,
.....	0080, 0112, 0119, 0139, 0140
Zenith.....	0055, 0061, 0071,
.....	0073, 0091, 0109, 0121, 0140

**TV/DVD Combo**

(TV / AUX 1 / AUX 2 Buttons)

Aiwa.....	5047
Apex.....	5015
Broksonic.....	5037
JVC.....	5010
Sansui.....	5022
Toshiba.....	5027

**TV/VCR Combo**

(TV / AUX 1 / AUX 2 Buttons)

Broksonic.....	5038
GE.....	5067
Hitachi.....	5058, 5059
JVC.....	5031
Panasonic.....	5011, 5034
Philips.....	5029, 5030
Quasar.....	5063, 5064
RCA.....	5060, 5065
Samsung.....	5043, 5057

Sharp.....	5028, 5035
Sony.....	5026
Sylvania.....	5044
Toshiba.....	5024
Zenith.....	5061

**TV/DVD/VCR Combo**

(TV / AUX 1 / AUX 2 Buttons)

Samsung.....	5062
Sylvania.....	5046
Toshiba.....	5025

**VCR**

(AUX 1 / AUX 2 Buttons)

Admiral.....	1073, 1074, 1101
Aiko.....	1056
Aiwa.....	1055
Akai.....	1044, 1045,
.....	1068, 1069, 1080, 1093
Audiovox.....	1051
Bell & Howell.....	1048
Broksonic.....	1023, 1049
Calix.....	1051
Canon.....	1053, 1054
Capehart.....	1067, 1083
Carver.....	1060, 1110
CCE.....	1056, 1059
Challenger.....	1001, 1023
Citizen.....	1050, 1051, 1052,
.....	1056, 1095
Colorlyme.....	1046, 1096
Craig.....	1050, 1051,
.....	1059, 1085, 1090, 1105
Curtis Mathes.....	1043, 1046,
.....	1050, 1053, 1054, 1077,
.....	1079, 1112
Daewoo.....	1014, 1052, 1055,
.....	1056, 1067, 1083, 1102
Daytron.....	1067, 1083, 1102
Denon.....	1088
Dimensia.....	1043, 1112
Dixon.....	1013, 1021, 1036, 1103
Electrohome.....	1051, 1090
Emerson.....	1044, 1049, 1051,
.....	1052, 1053, 1055, 1061,
.....	1069, 1087, 1090, 1106
Fisher.....	1048, 1089, 1105
Fuji.....	1045, 1053
Funai.....	1055, 1095
Garrard.....	1055
GE.....	1040, 1043, 1050,
.....	1053, 1054, 0070, 0079,
.....	0112
Go Video.....	0021, 0024, 0026,
.....	0028, 0079, 0081, 0085,
.....	0086
Goldstar.....	0046, 0051,
.....	0079, 0090, 0092
Gradiente.....	0055, 0090
Harman Kardon.....	0046, 0110
Harwood.....	0059
Hitachi.....	0025, 0036, 0037,
.....	0057, 0058, 0065, 0068,
.....	0070, 1088
JBL.....	1098
JCPenney.....	1046, 1047, 1048,
.....	1049, 1050, 1051, 1053,
.....	1059, 1060, 1054, 1057,
.....	1058, 1065, 1079, 1085,
.....	1088, 1090
Jensen.....	1057, 1058, 1068
JVC.....	1000, 1019, 1046,
.....	1047, 1048, 1068, 1071,
.....	1087, 1088

Kenwood.....	1046, 1047, 1048,
.....	1068, 1071, 1077
KLH.....	1059
Kodak.....	1051, 1053
LG.....	1051
Lloyds.....	1077, 1095, 1105
Logik.....	1059, 1085
LXI.....	1051
Magnasonic.....	1085, 1090,
.....	1102
Magnavox.....	1008, 1053, 1054,
.....	1060, 1064, 1085, 1110
Marantz.....	1046, 1047, 1048,
.....	1053, 1060, 1077, 1092,
.....	1110
Matsushita.....	1053
Memorex.....	1033, 1048, 1050,
.....	1051, 1053, 1055, 1064,
.....	1073, 1074, 1088, 1090,
.....	1091, 1097, 1105
MGA.....	1061, 1069
MGN.....	1079
Minolta.....	1057, 1058, 1065,
.....	1088
Mitsubishi.....	1003, 1005, 1006,
.....	1057, 1058, 1061, 1069,
.....	1071, 1090
Montgomery Ward.....	1073,
.....	1074
Motorola.....	1053, 1073, 1074
MTC.....	1050, 1085
Multitech.....	1050, 1055, 1059
NEC.....	1046, 1047, 1048,
.....	1068, 1071, 1077, 1092
Nikko.....	1051
Olympus.....	1053
Optimus.....	1051, 1073,
.....	1074, 1090, 1094
Optonica.....	1062
Orion.....	1087, 1090, 1106
Panasonic.....	1002, 1004, 1009,
.....	1020, 1053, 1054,
.....	1066, 1085, 1105
Pentax.....	1057, 1058, 1065,
.....	1070, 1077, 1088
Philco.....	1053, 1054, 1060,
.....	1088, 1106
Philips.....	1017, 1018, 1053,
.....	1060, 1062, 1110
Pioneer.....	1047, 1057, 1071,
.....	1075, 1078, 1104
Portland.....	1067, 1083
Proscan.....	1043, 1112
Proton.....	1085
Quasar.....	1053, 1054
Radio Shack.....	1051, 1062,
.....	1074, 1090
Radio Shack/Realistic.....	1048,
.....	1050, 1051, 1053, 1054
.....	1055, 1062, 1073
Radix.....	1051
RCA.....	1012, 1016, 1043, 1044,
.....	1050, 1053, 1057, 1058,
.....	1065, 1070, 1078, 1079,
.....	1088, 1107, 1108, 1112
Realistic.....	1048, 1050, 1051,
.....	1052, 1053, 1054, 1055,
.....	1062, 1073, 1074, 1079,
.....	1090, 1094, 1097, 1105
Ricoh.....	1072, 1076
Runco.....	1064
Samsung.....	1029, 1031, 1035,
.....	1039, 1050, 1052,
.....	1079, 1095
Sansui.....	1047, 1068, 1071,

.....	1085
Sanyo.....	1022, 1048, 1050,
.....	1089, 1097, 1105
Scott.....	1049, 1052, 1061, 1090
Sears.....	1048, 1051, 1053,
.....	1057, 1058, 1065, 1077,
.....	1088, 1089, 1090, 1097, 1105
Sharp.....	1015, 1062, 1073,
.....	1074, 1091, 1094, 1101
Shintom.....	1045, 1058, 1059,
.....	1085
Signature.....	1073, 1074
Signature 2000.....	1097, 1101
Singer.....	1053, 1059,
.....	1072, 1076, 1085
Sony.....	1007, 1045, 1063,
.....	1080, 1082, 1084, 1098, 1099
STS.....	1053, 1065
Sylvania.....	1030, 1032, 1053,
.....	1054, 1055, 1060, 1061, 1110
Symphonic.....	1055, 1077,
.....	1095, 1105
Tandy.....	1048
Tashiko.....	1051
Tatung.....	1068
Teac.....	1055, 1068, 1107
Technics.....	1053, 1066
Teknika.....	1051, 1053, 1055
.....	1090
Toshiba.....	1010, 1011, 1052,
.....	1057, 1061, 1069, 1100,
.....	1102, 1105, 1109
Totevision.....	1050, 1051, 1090
Unitec.....	1095
Unitech.....	1050
Vector Research.....	1046, 1047,
.....	1052, 1077
Video Concepts.....	1046, 1047,
.....	1052, 1069, 1077
Wards.....	1050, 1051, 1052,
.....	1053, 1055, 1057, 1058,
.....	1059, 1062, 1065, 1073,
.....	1074, 1079, 1090, 1091,
.....	1094, 1105, 1108, 1110
White Westinghouse.....	1095
XR-1000.....	1053, 1055, 1059
Yamaha.....	1046, 1047,
.....	1048, 1068, 1077
Zenith.....	1027, 1038, 1045,
.....	1064, 1072, 1076, 1093

**DVD/VCR Combo**

(AUX 1 / AUX 2 Buttons)

Go Video.....	1026, 1028
Hitachi.....	1025
JVC.....	1000
Samsung.....	1031
Sanyo.....	1022
Zenith.....	1027

**DVR / PVR**

(AUX 1 / AUX 2 Buttons)

Philips.....	5042
RePlay.....	5156
Tivo.....	5111



### Warranty – U.S. and Canada

The Warranty below is valid only for sales to consumers in the United States or Canada. KLIPSCH, L.L.C. ("KLIPSCH") warrants this product to be free from defects in materials and workmanship (subject to the terms set forth below) for a period of five (5) years from the date of purchase. During the Warranty period, KLIPSCH will repair or replace (at KLIPSCH's option) this product or any defective parts (excluding electronics and amplifiers). For products that have electronics or amplifiers, the Warranty on those parts is for a period of one (1) year from the date of purchase.

To obtain Warranty service, please contact the KLIPSCH authorized dealer from which you purchased this product. If your dealer is not equipped to perform the repair of your KLIPSCH product, it can be returned, freight paid, to KLIPSCH for repair. Please call KLIPSCH at 1-800-KLIPSCH for instructions. You will need to ship this product in either its original packaging or packaging affording an equal degree of protection.

Proof of purchase in the form of a bill of sale or receipted invoice, which is evidence that this product is within the Warranty period, must be presented or included to obtain Warranty service.

This Warranty is invalid if (a) the factory-applied serial number has been altered or removed from this product or (b) this product was not purchased from a KLIPSCH authorized dealer. You may call 1-800-KLIPSCH to confirm that you have an unaltered serial number and/or you purchased from a KLIPSCH authorized dealer.

This Warranty is only valid for the original purchaser and will automatically terminate prior to expiration if this product is sold or otherwise transferred to another party.

This Warranty does not cover cosmetic damage or damage due to misuse, abuse, negligence, acts of God, accident, commercial use or modification of, or to any part of, the product. This Warranty does not cover damage due to improper operation, maintenance or installation, or attempted repair by anyone other than KLIPSCH or a KLIPSCH dealer which is authorized to do KLIPSCH warranty work. Any unauthorized repairs will void this Warranty. This Warranty does not cover product sold AS IS or WITH ALL FAULTS.

REPAIRS OR REPLACEMENTS AS PROVIDED UNDER THIS WARRANTY ARE THE EXCLUSIVE REMEDY OF THE CONSUMER. KLIPSCH SHALL NOT BE LIABLE FOR ANY INCIDENTAL OR CONSEQUENTIAL DAMAGES FOR BREACH OF ANY EXPRESS OR IMPLIED WARRANTY ON THIS PRODUCT. EXCEPT TO THE EXTENT PROHIBITED BY LAW, THIS WARRANTY IS EXCLUSIVE AND IN LIEU OF ALL OTHER EXPRESS AND IMPLIED WARRANTIES WHATSOEVER, INCLUDING BUT NOT LIMITED TO, THE WARRANTY OF MERCHANTABILITY AND FITNESS FOR A PARTICULAR PURPOSE.

Some states do not allow the exclusion or limitation of incidental or consequential damages or implied warranties so the above exclusions may not apply to you. This Warranty gives you specific legal rights, and you may have other rights, which vary from state to state.

### Warranty Outside the United States and Canada

The Warranty on this product if it is sold to a consumer outside of the United States or Canada shall comply with applicable law. To obtain any applicable warranty service, please contact the dealer from which you purchased this product, or the distributor that supplied this product.

### FCC Information

This device complies with Part 15 of the FCC Rules. Operation is subject to the following: (1) This device may not cause harmful interference, and (2) this device must accept any interference received, including interference that may cause undesired operation.

This equipment has been tested and found to comply with the limits for a Class B digital device, pursuant to Part 15 of the FCC Rules. These limits are designed to provide reasonable protection against harmful interference in a residential installation. This equipment generates, uses and radiates radio frequency energy and, if not installed and used in accordance with the instruction, may cause harmful interference to radio communications. However, there is no guarantee that interference will not occur in a particular installation.

In accordance with FCC requirements, changes or modifications not expressly approved by Klipsch could void the user's authority to operate this product.

This device generates and uses radio frequency (RF) energy, and if not installed and used properly, this equipment may cause interference to radio and television reception.

If this equipment does cause interference to radio or television reception (which you can determine by unplugging the unit), try to correct the interference by one or more of the following measures:

- Re-orient the receiving antenna (that is, the antenna for the radio or television that is "receiving" the interference).
- Move the unit away from the equipment that is receiving interference.
- Plug the unit into a different wall outlet so that the unit and the equipment receiving interference are on different branch circuits.

If these measures do not eliminate the interference, please consult your dealer or an experienced radio/television technician for additional suggestions.

Also, the Federal Communications Commission has prepared a helpful booklet, "How To Identify and Resolve Radio TV Interference Problems." This booklet is available from the U.S. Government Printing Office, Washington, DC 20402. Please specify stock number 004-000-00345-4 when ordering copies.

This product complies with DHHS Rules 21 CFR Subchapter J. Applicable at the date of manufacture.

This Class B digital apparatus complies with Canadian ICES-003. Cet appareil numérique de la classe B est conforme à la norme NMB-003 du Canada.

### FCC Declaration Of Conformity

Trade Name:	Klipsch Audio Technologies
Product Name:	DVD Audio/Video System
Model Number:	CS-700
Responsible Party	
Manufacturer:	Klipsch Audio Technologies
Address:	3502 Woodview Trace, Suite 200 Indianapolis, IN 46268
Telephone:	317-860-8100
Date:	1/15/2006

These devices were tested and found to comply with Part 15 of the FCC Rules. Operation is subject to the following conditions: The devices may not cause harmful interference, and the devices must accept any interference received, including interference that may cause undesired operation.

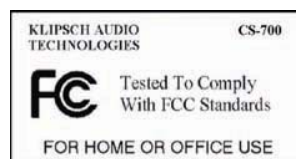

## Appendix I - Connection Overview

Understanding the basics of how Input and Output jacks work will assist you in connecting components to your Klipsch system.

### Input jacks are connected to peripheral components

Your cable box, satellite box, or HD receiver box would connect to your Klipsch system's input jacks to bring the signal INTO the Klipsch system so you can control everything (sound and picture) from the Klipsch system.

### Output jacks send the signal OUT from your Klipsch system to the TV (for video) and to the speaker system (for audio)

For instance, in order to see the DVD movie you're playing in your Klipsch system, you must connect cables to the TV so you can see the picture on the TV screen. Therefore, you connect a cable to the output jack on the Klipsch system (sending the DVD signal OUT to the TV) and connect the other end of that cable to the matching input jack(s) on the TV.

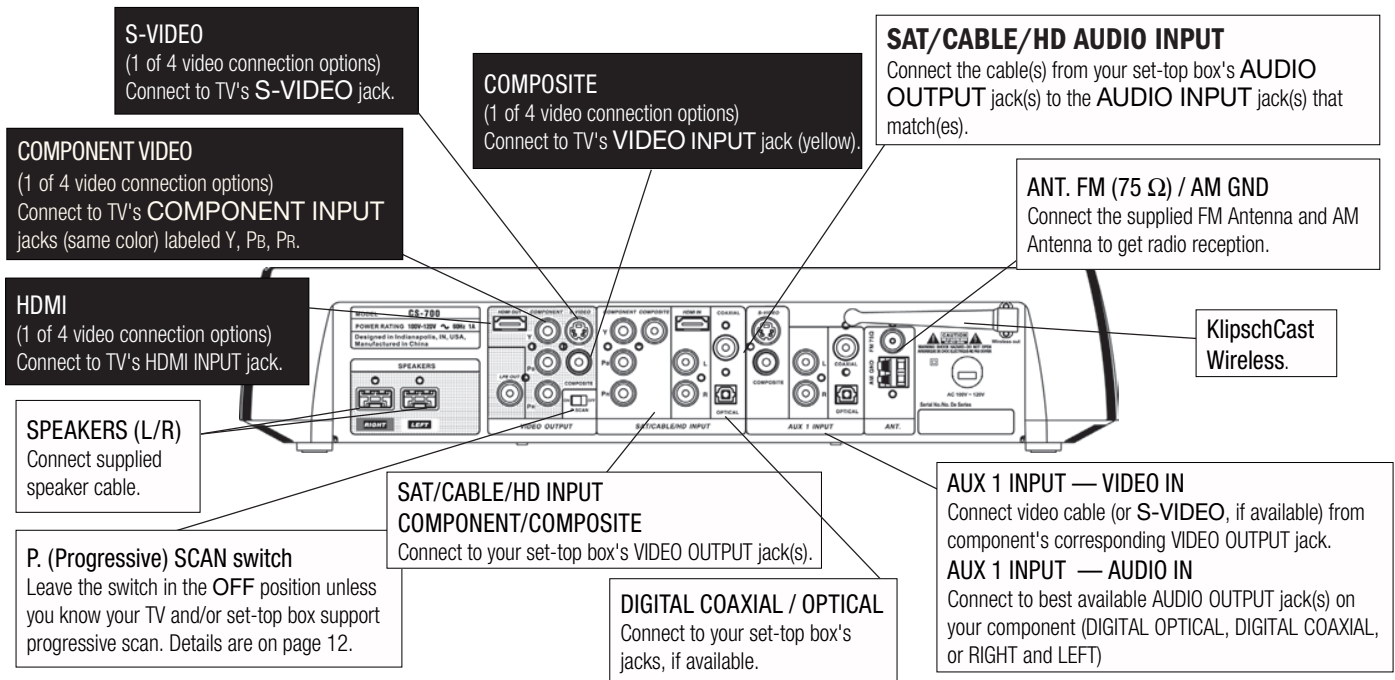

Audio Connection Options	Cables	Jacks
DIGITAL AUDIO OPTICAL	Not supplied	OPTICAL
DIGITAL AUDIO COAXIAL	Not supplied	COAXIAL
AUDIO RIGHT and LEFT	Supplied	L R

Video Connection Options	Cables	Jacks
COMPONENT Video is considered excellent video quality because the video is separated into three parts Y = Luminance (black & white part of signal) PB= Chrominance (color) minus blue PR = Chrominance minus red	<b>OR</b> Bundled Set Not supplied	COMPONENT Y PB PR
S-VIDEO (separate video) provides very good video quality. Even though there is only one cable, the chrominance and luminance are kept separate from the main signal.	 S-VIDEO cable Not supplied	S-VIDEO
COMPOSITE (yellow) provides good video quality.	 COMPOSITE video cable Supplied	COMPOSITE
This is a digital connection.	 HDMI cable Not supplied	HDMI



# Power

# Detail

# Emotion

For over 60 years, we've made speakers for people who are as passionate about great sound as we are. That's why every Klipsch speaker is horn-loaded to create a remarkably accurate listening experience for your music and movies. From our smallest satellites to our acclaimed professional theater installations, our speakers deliver sound that's so lifelike, you have to feel it to believe it.

THE ULTIMATE SOUND EXPERIENCE™